

03

Consolidated table of figures of VM Books, Courses other documents (research papers of Dr S. K. Kapoor, Ved Ratan)

Just click on the topic by pressing ctrl button

Contents

1 Cube.....	4
2 Structural components of prism part of cube	5
3 Structural components of second prism part of the cube.....	6
4 Set up of a pair of prisms	6
5 Sub cubes 1 to 8.....	11
7 Higher Spaces.....	14
Universe is 3-space	14
Universe is 4-space	14
Universe is 5-space	14
Universe is 6-space	14
3-space.....	15
4-space.....	15
5-space.....	15
6-space.....	16
Cube with point in center	16
8 Cube wighin cube.....	17
Cube within square	17
Lord Shiv	20
Hyper cube 5.....	20
9 Ten Bramhas	21
10 Spatial order formulation.....	24
11 Ten directional frame.....	24
12 Chatuspeeth.....	25
Chatuspeeth format.....	27
13 Chatuspeeth format of TCV values of Upsutras	32
14 Perfect number	37
15 Ten folds of formulations Surya	37
16 13 versions of Hyper cube 6	38
17 11 versions of Hyper cube 5	40

18	9 versions of Hyper cube 4.....	41
19	7 versions of Hyper cube 3.....	42
20	Hyper cube 1 to 6.....	42
	Damru.....	43
	Hyper cube 7.....	43
21	Eight directional frame.....	44
22	Dimensions.....	45
23	Om formulation.....	46
24	Bindu sarovar.....	46
25	Polygon 12 figures.....	46
26	Northern hemisphere.....	47
27	3, 4 and 5 spaces.....	48
28	Dimensional split spectrum format.....	52
29	Vedic Alphabet.....	53
30	Divya Ganga Parvah.....	57
31	Transcendental cavity.....	59
32	Place value systems.....	60
	Grid 5 x 7.....	63
	Grid 6 x 8.....	63
	7 place value system.....	63
	4 x 4 grid.....	63
33	Separation plate of 8 octants.....	65
34	Half unit hyper cube.....	66
35	Param Vihom (Transcendental space).....	66
	Thirteen 13 geometries of 6-space.....	66
36	11 geometries of 5-space.....	67
37	9 signatures geometries of 4-space.....	68
38	Synthesis value 31.....	68
39	120 hyper cubes.....	69
40	Vedic alphabet.....	69
41	Cube structure.....	73
42	Separation base plate – synthetic cube of eight sub cube.....	74
43	Eight sub cubes.....	75
44	Home of lord brahma and vidhyadhari within shila.....	76
45	Northern hemisphere.....	76
46	Eight directional frame.....	76

47	Ganita Sutra 1 figure	78
48	Srimad Bhagwad Geeta study zone.....	78
49	Symbols Om Aum.....	78
	Sama parvah	80
	Divya ganga parvah.....	80
50	Satha patya figures.....	81
	Domain split spectrum.....	81
51	Northern hemisphere	82
52	5 geometries of 2-space	84
53	3 space origin of 2-space	84
54	5-space origin of 4-space of spatial order	84
55	3-space dimension of 5-space.....	84
56	Transcendental cavity at origin seat of creative cap of ten components	84
57	Synthesis of pair of transcendence ranges in spatial dimension of 4-space of 5-space origin	84
58	Paired pairs of synthesized transcendence ranges of linear order of all four spatial dimensions of 4-space of 5-space origin	85
	Seven geometries of 3-space	85
59	Nine signatures geometries of 4-space	86
60	Eleven signatures geometries of 5-space	86
61	Thirteen geometries of 6-space.....	87
62	Ardh narishwar	88
63	Agni stabh	88
64	Solid plus solid.....	90
65	Fire edges.....	90

1 Cube

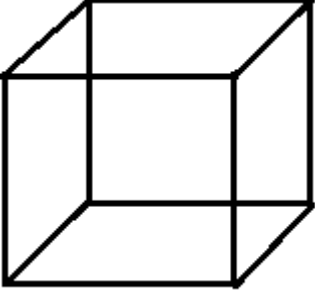
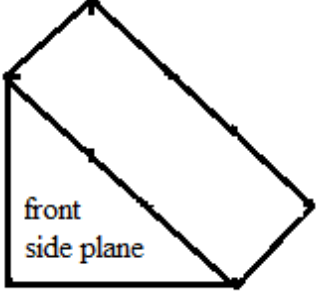
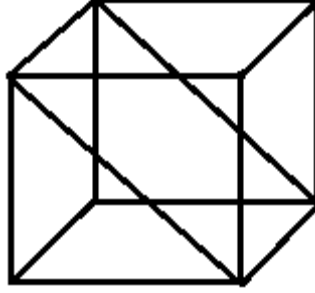
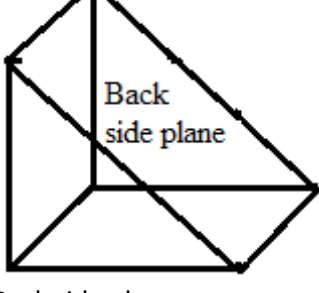
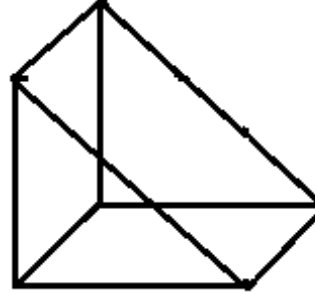
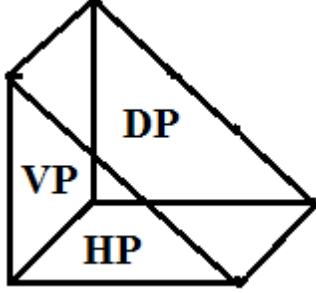
<p>C1.1</p>	 <p>Cube</p>	<p>C1.4</p>	 <p>front side plane</p> <p>Front side plane</p>
<p>C1.2</p>	 <p>Cube with diagonal plane</p>	<p>C1.5</p>	 <p>Back side plane</p> <p>Back side plane</p>
<p>C1.3</p>	 <p>Half cube / prisam</p>	<p>C1.6</p>	 <p>DP</p> <p>VP</p> <p>HP</p> <p>Half cube / prisam</p>

2 Structural components of prism part of cube

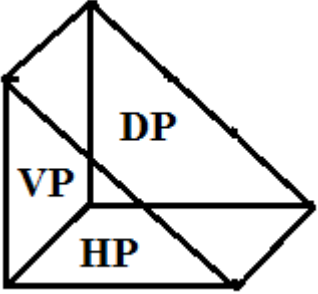
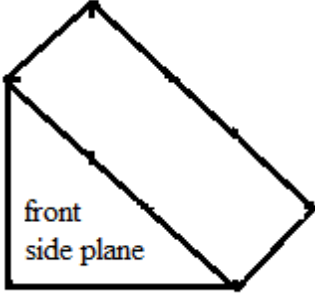
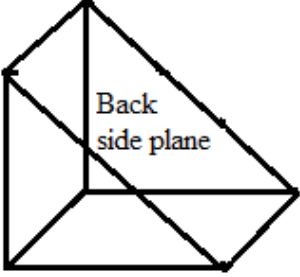
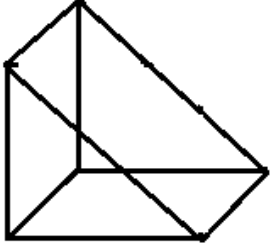

Planes	Structural figure	Structural components	Total Structural components
Vertical plane	 <p style="text-align: center;">C2.1.1</p>	9	9
Horizontal plane		6	15
Diagonal plane		3	18
Front side plane	 <p style="text-align: center;">C2.1.2</p>	1	19
Back side plane	 <p style="text-align: center;">C2.1.3</p>	1	20
Volume	 <p style="text-align: center;">C2.1.4</p>	1	21

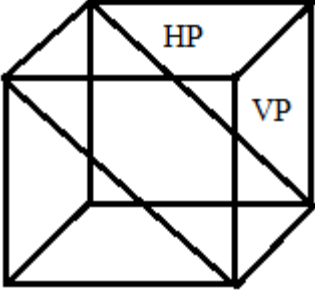

3 Structural components of second prism part of the cube

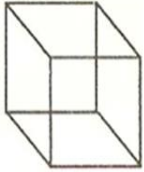
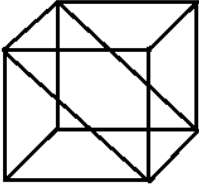
Planes	Structural figure	Structural components	Total Structural components
Vertical plane	 C2.3.1	6	6
Horizontal plane		3	9
Diagonal plane		0	9
Front side plane		1	10
Back side plane		1	11
Volume		1	12

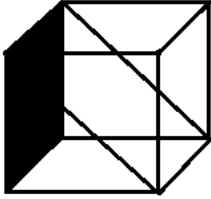
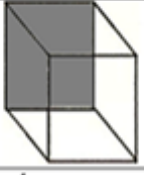
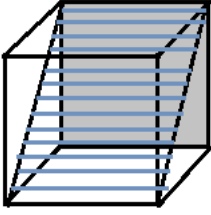
4 Set up of a pair of prisms

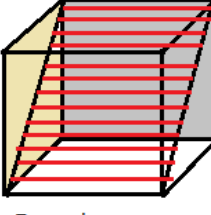

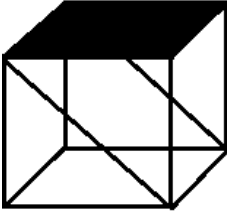

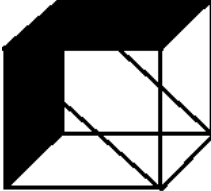
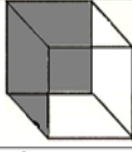
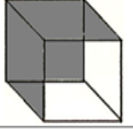
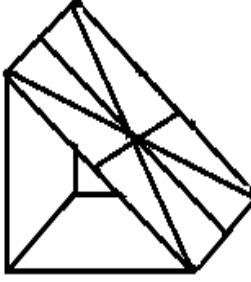
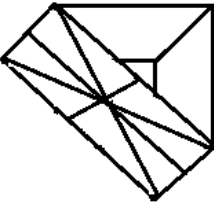
Sub cube	Set up of a pair of prisms	First prism (lower prism) Structural components	Second prism structural components
First sub cube  Structural components 8 corner points, 12 edges 6 surfaces, 1 volume = Total 27 C2.4.1	Upper prism  Lower prism C2.4.2	Vertical Plane = 9 Horizontal Plane = 6 Diagonal Plane = 3 Front side Plane = 1 Back side plane = 1 Volume = 1 ===== Total 21	6 3 0 1 1 1 ===== 12

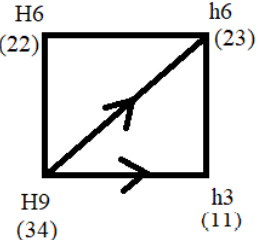
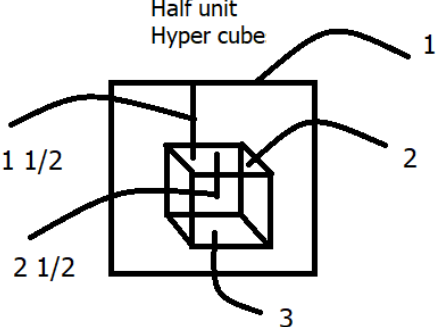
<p>Second sub Cube</p>  <p>Structural components 4 corner points, 8 edges 5 surfaces, 1 volume = Total 18</p> <p>C2.4.3</p>	<p>Upper prism</p>  <p>Lower prism C2.4.4</p>	<p>Vertical Plane = 0</p> <p>Horizontal Plane = 6</p> <p>Diagonal Plane = 3</p> <p>Front side Plane = 1</p> <p>Back side plane = 1</p> <p>Volume = 1</p> <p>=====</p> <p>Total 12</p>	<p>6</p> <p>3</p> <p>0</p> <p>1</p> <p>1</p> <p>1</p> <p>====</p> <p>12</p>
<p>Third</p> <p>Third sub cube</p>  <p>Structural components 4 corner points, 8 edges 5 surfaces, 1 volume = Total 18</p> <p>C2.4.5</p>	<p>Back prim</p>  <p>Front prim C2.4.6</p>	<p>Front prism</p> <p>Vertical Plane = 9</p> <p>Horizontal Plane = 3</p> <p>Diagonal Plane = 3</p> <p>Front side Plane = 1</p> <p>Back side plane = 1</p> <p>Volume = 1</p> <p>=====</p> <p>Total 18</p>	<p>Back prism</p> <p>0</p> <p>6</p> <p>0</p> <p>1</p> <p>1</p> <p>1</p> <p>====</p> <p>9</p>
<p>Fourth</p> <p>Fourth sub Cube</p>  <p>Structural components 2 corner points, 5 edges 4 surfaces, 1 volume = Total 12</p> <p>C2.4.7</p>	<p>Back prim</p>  <p>Front prim C2.4.8</p>	<p>Front prism</p> <p>Vertical Plane = 6</p> <p>Horizontal Plane = 3</p> <p>Diagonal Plane = 2</p> <p>Front side Plane = 0</p> <p>Back side plane = 1</p> <p>Volume = 1</p> <p>=====</p> <p>Total 13</p>	<p>Back prism</p> <p>0</p> <p>6</p> <p>0</p> <p>1</p> <p>0</p> <p>1</p> <p>====</p> <p>8</p>
<p>Fifth</p>	<p>Upper prism</p>	<p>Vertical Plane = 6</p> <p>Horizontal Plane = 6</p> <p>Diagonal</p>	<p>6</p> <p>0</p>

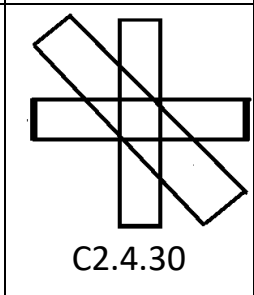
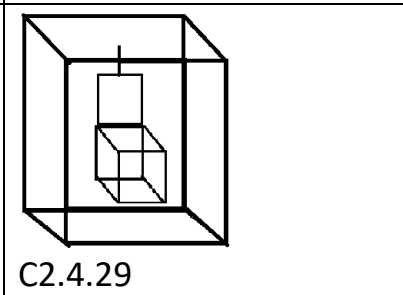
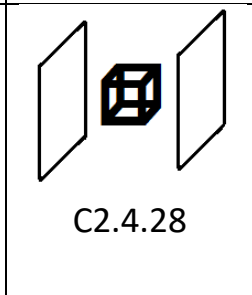
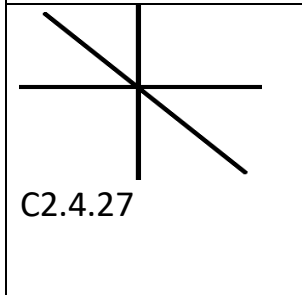
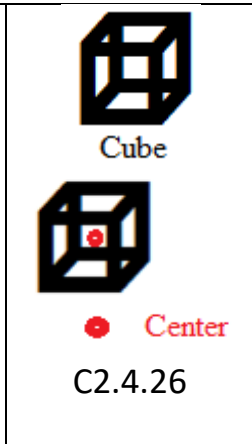
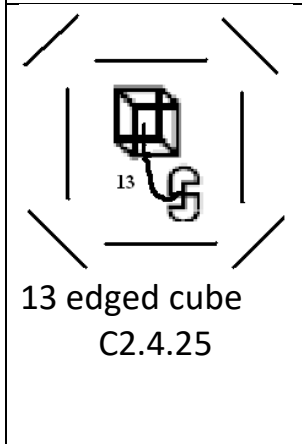
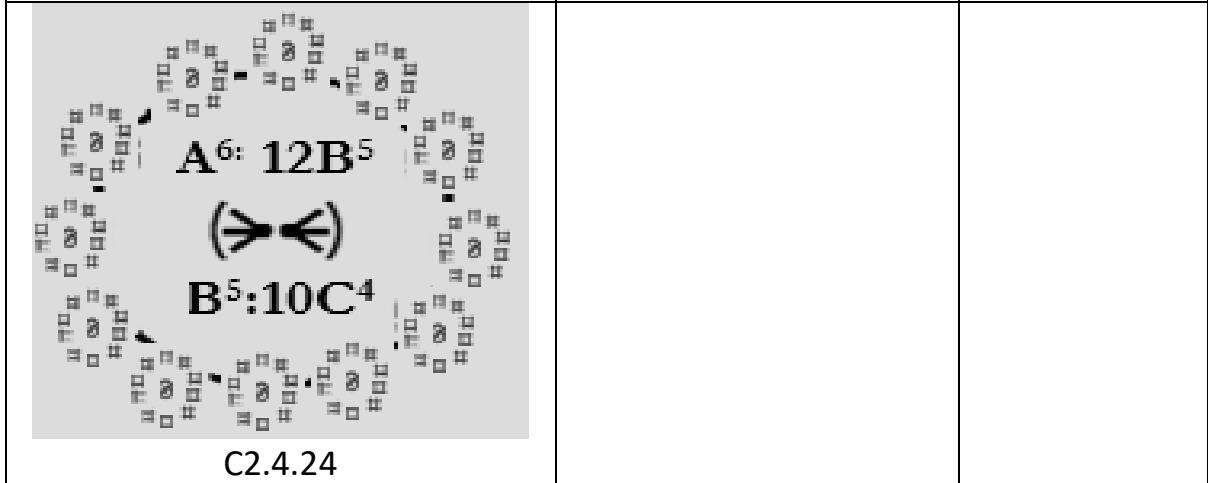
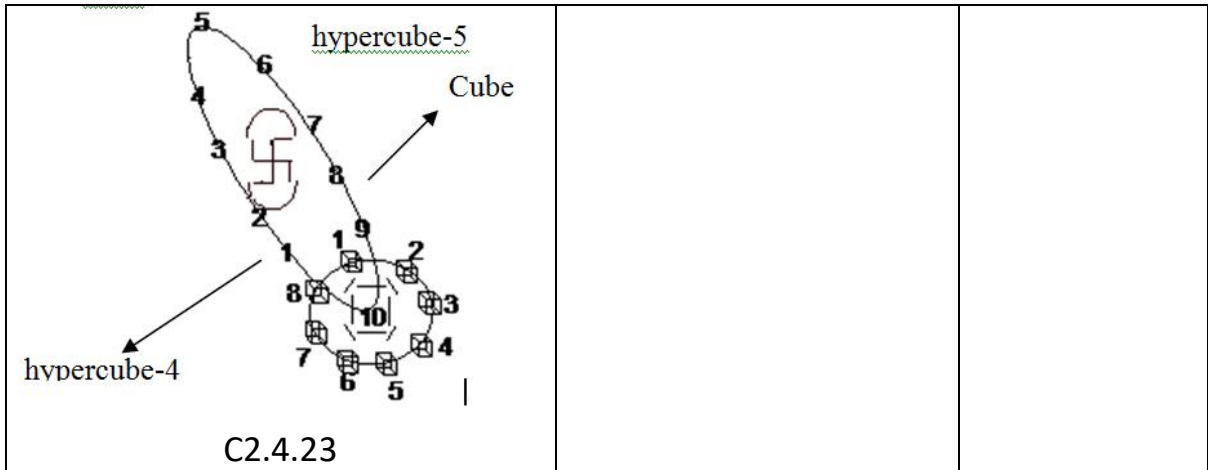
<p>Fifth sub cube</p>  <p>Structural components 4 corner points, 8 edges 5 surfaces, 1 volume = Total 18</p> <p>C.2.4.9</p>	 <p>Lower prism C2.4.10</p>	<p>Plane = 3 Front side Plane = 1 Back side plane = 1 Volume = 1</p> <p>=====</p> <p>Total 18</p>	<p>0 1 1 1</p> <p>====</p> <p>9</p>
<p>Sixth</p> <p>Sixth sub Cube</p>  <p>Structural components 2 corner points, 5 edges 4 surfaces, 1 volume = Total 12</p> <p>C2.4.11</p>	<p>Upper prism</p>  <p>Lower prism C2.4.12</p>	<p>Vertical Plane = 0 Horizontal Plane = 6 Diagonal Plane = 3 Front side Plane = 1 Back side plane = 1 Volume = 1</p> <p>=====</p> <p>Total 12</p>	<p>6 0 0 1 1 1</p> <p>====</p> <p>9</p>
<p>Seventh sub cube</p>  <p>Structural components 2 corner points, 5 edges 4 surfaces, 1 volume = Total 12</p> <p>C2.4.13</p>	<p>Eighth sub Cube</p>  <p>Structural components 1 corner points, 3 edges 3 surfaces, 1 volume = Total 8</p> <p>C2.4.14</p>		
 <p>C2.4.15</p>	<p>C2.4.13</p>  <p>C2.4.16</p>		

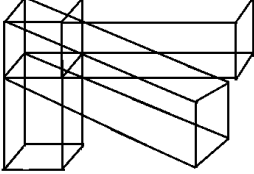
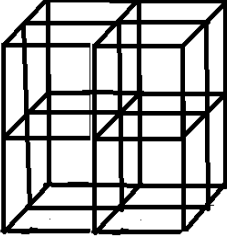
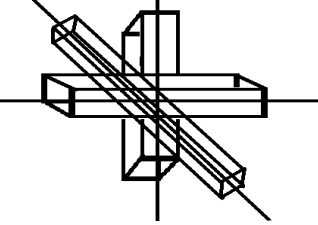
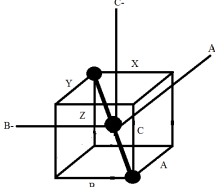
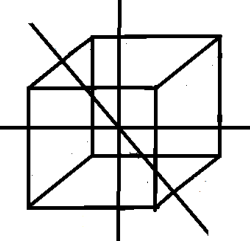
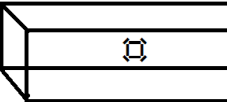
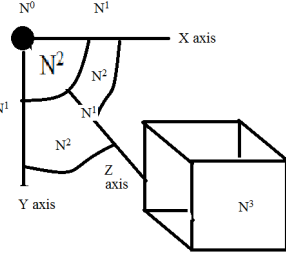
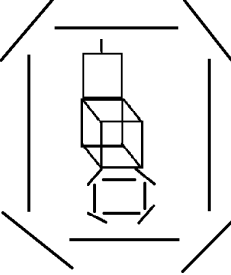

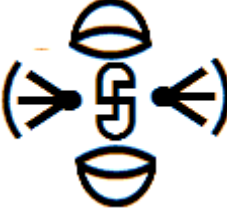
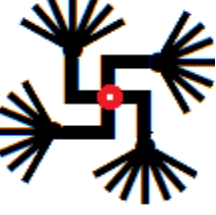
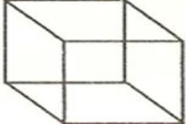

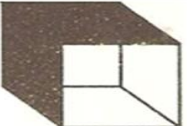
 <p>C2.4.17</p>	<p>Separation plate of 8 octants Central plate</p> <table border="1" data-bbox="533 385 746 600"> <tr> <td>9</td> <td>6</td> </tr> <tr> <td>6</td> <td>4</td> </tr> </table> <p>C2.4.18</p>	9	6	6	4		
9	6						
6	4						
<p> $9 \times 3 = 27$ $6 \times 3 = 18$ $6 \times 3 = 18$ $4 \times 3 = 12$ </p> <table border="1" data-bbox="304 855 539 1077"> <tr> <td>9</td> <td>6</td> </tr> <tr> <td>6</td> <td>4</td> </tr> </table> <p>Central plate</p> <p> $9 \times 2 = 18$ $6 \times 2 = 12$ $6 \times 2 = 12$ $4 \times 2 = 8$ </p> <p>C2.4.19</p>	9	6	6	4			
9	6						
6	4						
 <p>C2.4.20</p>							

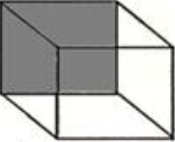
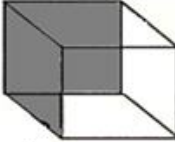
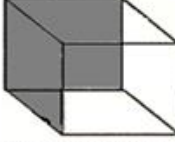
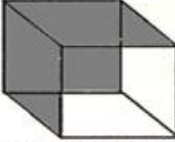

 <p>C2.4.31</p>	 <p>Eight sub cubes C2.4.32</p>	 <p>C2.4.33</p>	 <p>C2.4.34</p>		
 <p>C2.4.35</p>	<p>Home of Lord Brahma and Vidhyadh within Shila (शिला) / slab</p>  <p>C2.4.36 Shila Northern hemisphere</p>	 <p>C2.4.37</p>	 <p>C2.4.38 Brahma</p>		
 <p>shiv C2.4.39</p>	 <p>Vishnu C2.4.40</p>	 <p>Brahm C2.4.41</p>			
<p>First sub cube</p>  <p>Structural components 8 corner points, 12 edges 6 surfaces, 1 volume = Total 27</p>		<p>Second sub Cube</p>  <p>Structural components 4 corner points, 8 edges 5 surfaces, 1 volume = Total 18</p>		<p>5 Sub cubes 1 to 8</p>	
<p>Third sub cube</p>  <p>Structural components 4 corner points, 8 edges 5 surfaces, 1 volume = Total 18</p>		<p>Fourth sub Cube</p>  <p>Structural components 2 corner points, 5 edges 4 surfaces, 1 volume = Total 12</p>			
<p>C2.4.42</p>					

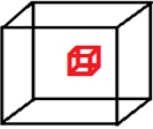
Fifth sub cube	Sixth sub Cube
	
Structural components 4 corner points, 8 edges 5 surfaces, 1 volume = Total 18	Structural components 2 corner points, 5 edges 4 surfaces, 1 volume = Total 12
Seventh sub cube	Eighth sub Cube
	
Structural components 2 corner points, 5 edges 4 surfaces, 1 volume = Total 12	Structural components 1 corner points, 3 edges 3 surfaces, 1 volume = Total 8

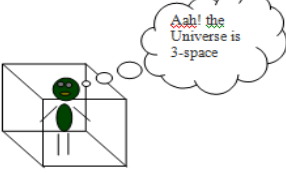
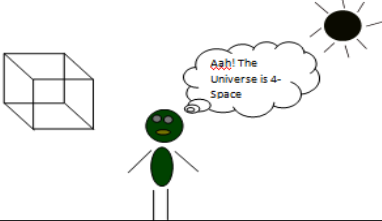
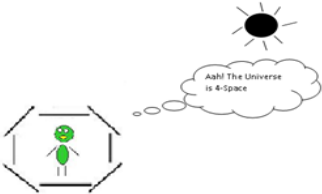
C2.4.43

FIG 9 3-space	FIG 10 2-space
	
3-space domain	3-space origin
FIG 11	FIG 12
	
FIG 13	FIG 14
	

C2.4.44

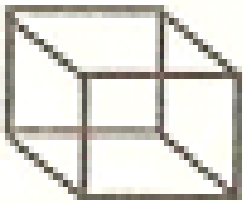
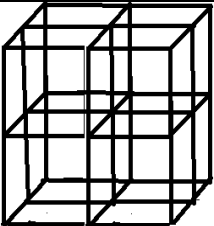
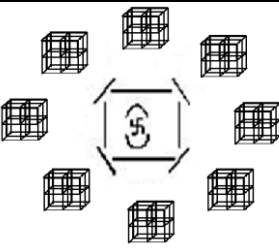
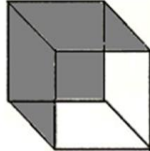
Cube	8 sub cubes	64 sub cubes	8 structural components
			Eighth sub Cube 
			Structural components 1 corner points, 3 edges 3 surfaces, 1 volume = Total 8

C2.4.45 6 Cubes, sub cubes and sub sub cubes

<p>2-space as domain</p> <p>Hyper cube 2 (0, 1, 2, 3) = 6</p> <p>Hyper cube 3 (1, 2, 3, 4) = 10</p> <p>3-space as origin of 2-space</p>	07		17		27		37			
	47		57		67		77			
	87		97		10		11			
					7		7			
	12		13		14		15			
	7		7		7		7			
	16		17		18		19			
7		7		7		7				
20		21		22		23				
7		7		7		7				
24		25		26		27		28		
7		7		7		7		7		

C2.4.46 **Cube within square**

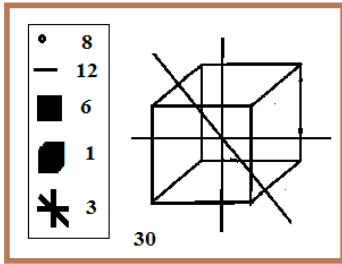

C2.4.47

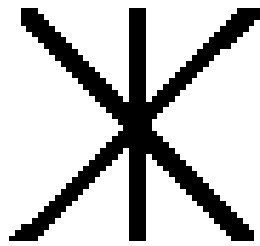

C2.4.48

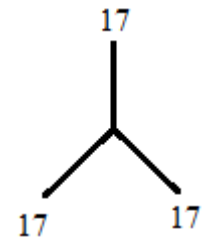

C2.4.49

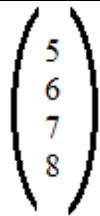

C2.4.50

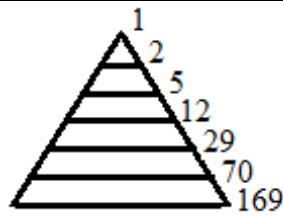



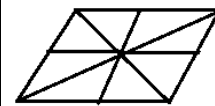





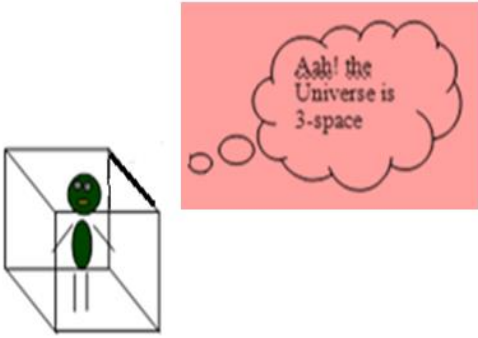







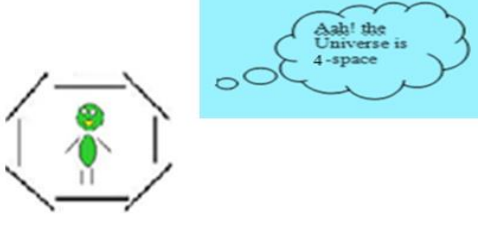
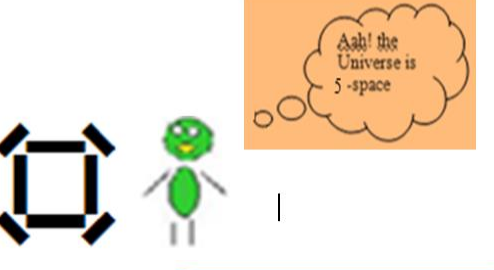

C2.4.51



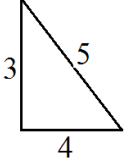
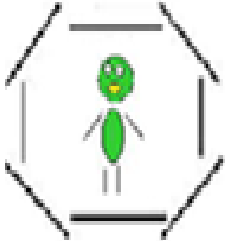

C2.4.52

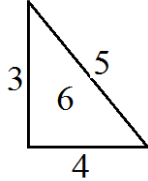
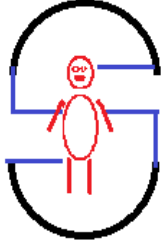
7 Higher Spaces

 <p>Seven geometries of 3-space</p> <div style="display: flex; justify-content: space-around; align-items: center;"> <div style="text-align: center;"> 0 signature</div> <div style="text-align: center;"> 1 signature</div> <div style="text-align: center;"> 2 signature</div> <div style="text-align: center;"> 3 signature</div> <div style="text-align: center;"> 4 signature</div> <div style="text-align: center;"> 5 signature</div> <div style="text-align: center;"> 6 signature</div> </div>	<p>Univers e is 3- space</p>
 	<p>Univers e is 4- space</p>
 	<p>Univers e is 5- space</p>
 	<p>Univers e is 6- space</p>

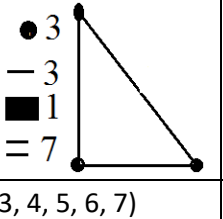
	<p>3-space</p>		
			<p>3-space</p>
			
			
	<p>(3, 4, 5)</p>		
	<p>4-space</p>		
			<p>4-space</p>
			
			
	<p>(3, 4, 5, 6)</p>		
	<p>5-space</p>		
			<p>5-space</p>
			

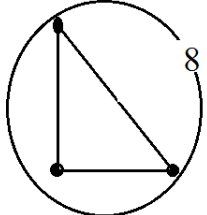
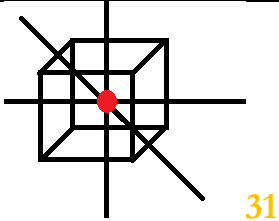
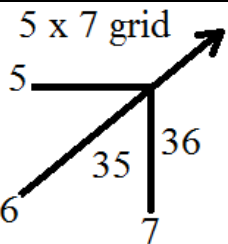
	 <p>(3, 4, 5, 6, 7)</p>		
	<p>6-space</p>   <p>(3, 4, 5, 6, 7, 8)</p>		6-space
	 <p>31</p>		Cube with point in center
	<p>5 x 7 grid</p> 		5 x 7 grid

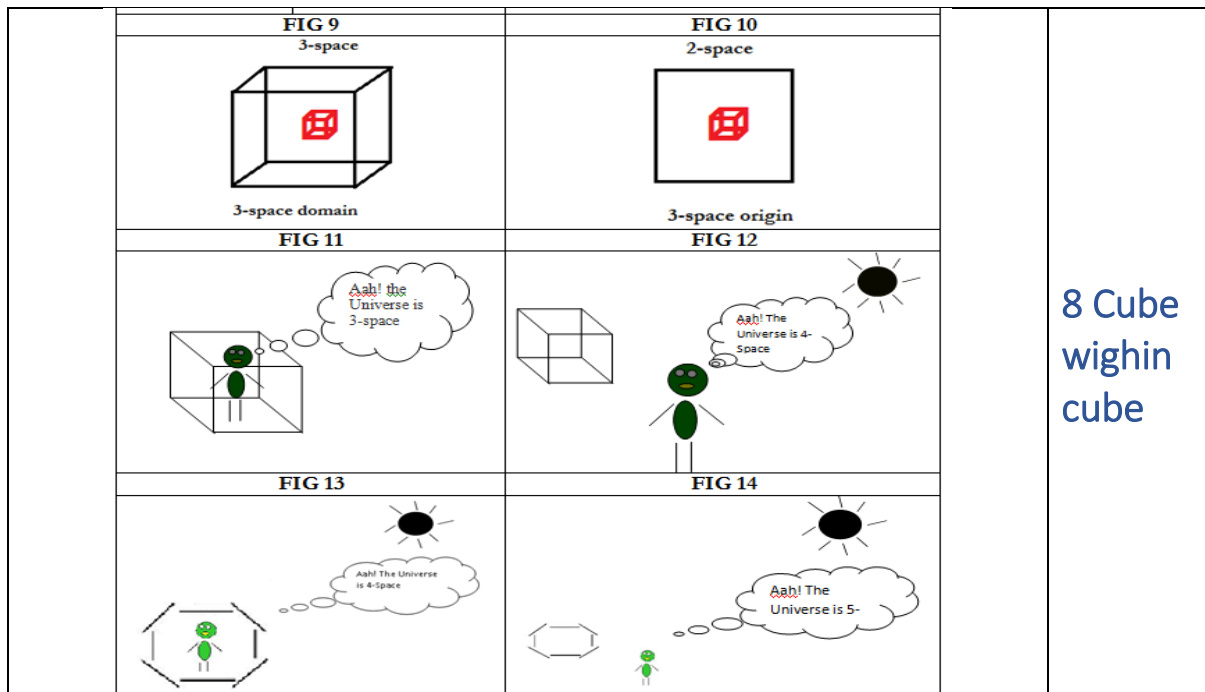

Cubes, sub cubes and sub sub cubes

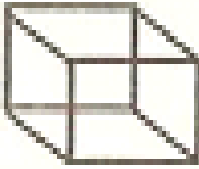
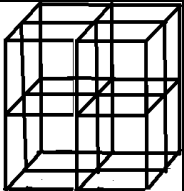
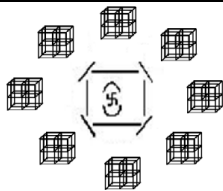
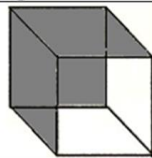
Cube	8 sub cubes	64 sub cubes	8 structural components
			<div style="border: 1px solid black; padding: 5px; width: fit-content; margin: 0 auto;"> Eighth sub Cube  Structural components 1 corner points, 3 edges 3 surfaces, 1 volume = Total 8 </div>

Cubes,
sub
cubes
and
sub
sub
cubes







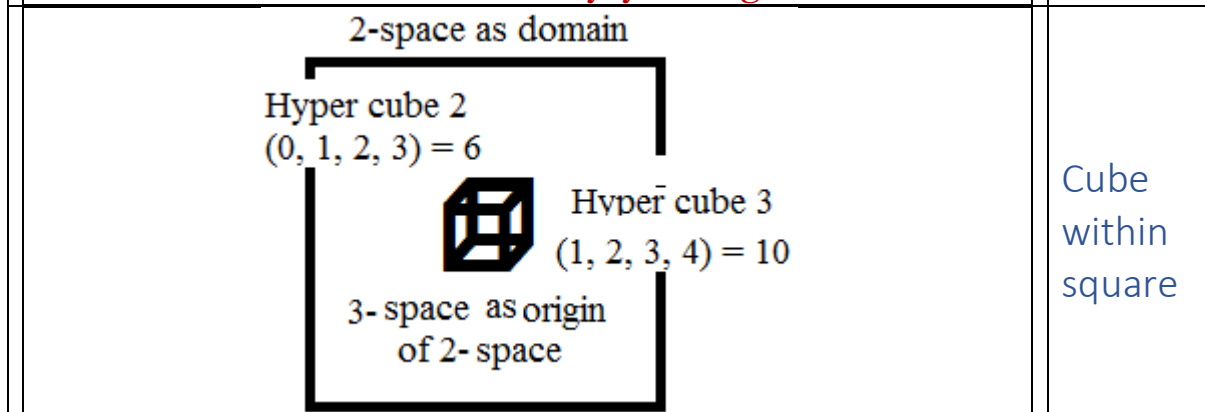

Note :-

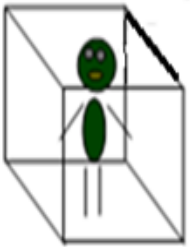
1. 513th sub sub cube, as set up of 8 inner most sub sub cubes, will with their 8 centers (in unmanifest forms) become formats of 8 letters (आनुरूप्ये) of Ganita Sutra 6, while the center of the main cube remains in both forms of manifest as well as unmanifest letter (ऽ) of Ganita Upsutra 9.

There are 8 ashtaks and 64 adhyeys of Rigved Samhita

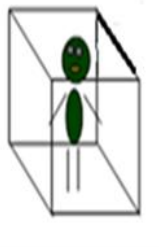

07	☒	17	☒	27	☒	37	☒		
47	☒	57	☒	67	☒	77	☒		
87	☒	97	☒	107	☒	117	☒		
127	☒	137	☒	147	☒	157	☒		
167	☒	177	☒	187	☒	197	☒		
207	☒	217	☒	227	☒	237	☒		
247	☒	257	☒	267	☒	277	☒	287	☒

S1.1	3-space	4-space	5-space	6-space
				
S1.2	3-space	4-space	5-space	6-space
				
	Glimpsing Rishi नारद / Narad (21)	Glimpsing Rishi ब्रह्मा / Brahma (29)	Glimpsing Rishi श्रीभगवान् / Sribhagwan (37)	Glimpsing Rishi नवब्रह्म / Nav Brahm (45)



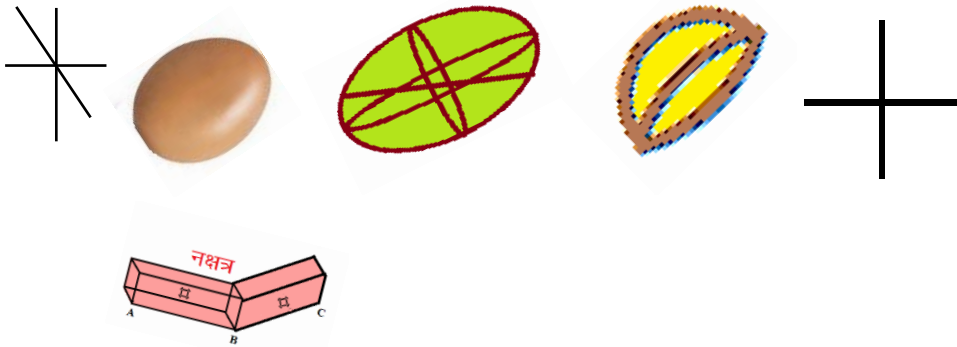
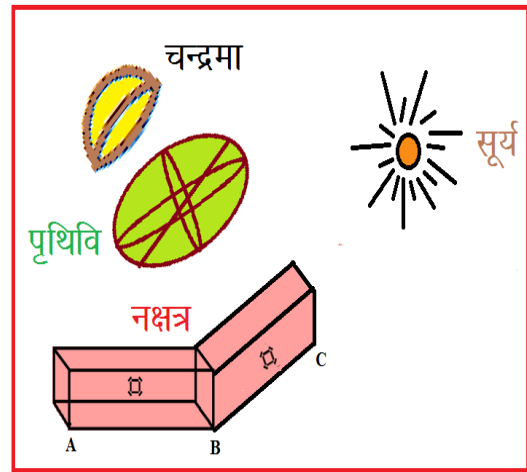
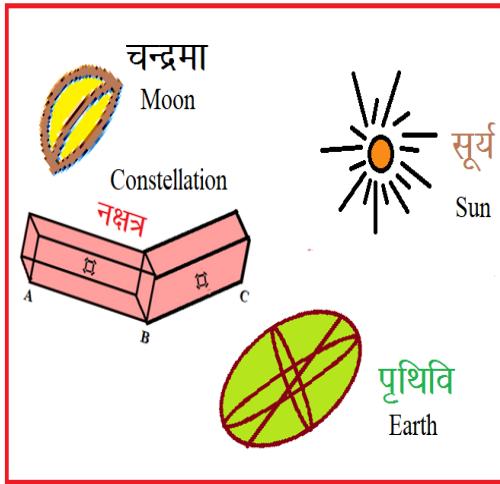

S1.3

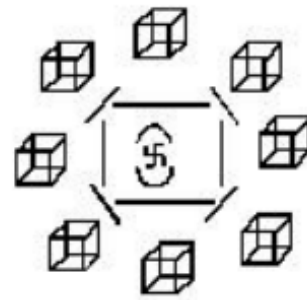

S1.4

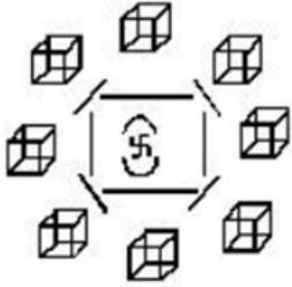

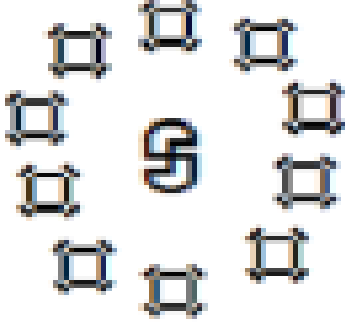

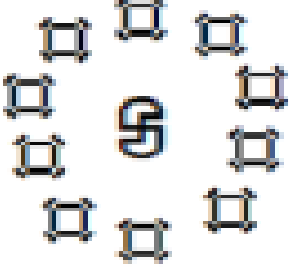





Idol of Lord Brahma



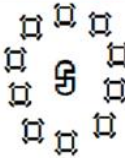

		
	Lord Brahma	Hyper cube 4
	Four heads	Four dimensions
	Pair of eyes in each head	Spatial (2-space) dimension
	Lotus seat of eight petals	Solid boundary of eight components
	Seat within cavity of heart of Transcendental lord shiv (5 head lord)	5-space as origin fold of 4-space.
S1.5		
	Lord Shiv	Hyper cube 5
	Five heads	Five dimensions
	Triple eyes in each head	Solid dimensional order
	Ten beautiful arms	Creative boundary of ten components
	Seat within cavity of heart of self referral lord Vishnu	6-space as origin of 5-space
S1.5		
	Idol of Lord Shiv	







9 Ten Bramhas

		
Lord Brahma	Ten brahmas in Shiv lok	Lord Shiv
		
4-space	Creative (4-space) boundary of ten components	5-space

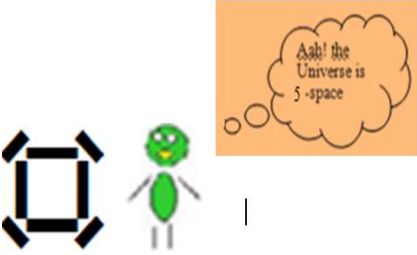
S1.7		Northern hemisphere
		Southern hemisphere

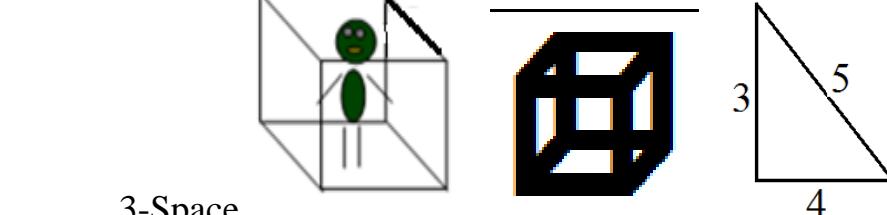
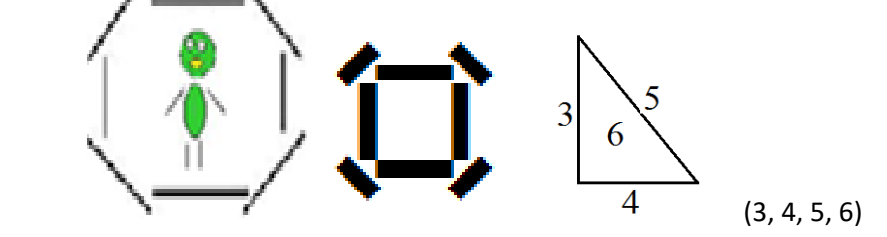
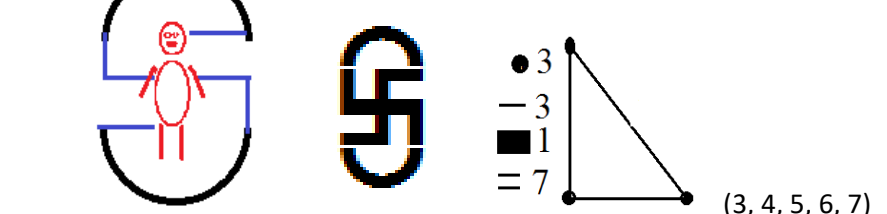
S.9 TO S1.15			Universe is 3-space
	S1.9		

S1.10		S1.11	Universe is 5-space
S1.12		S1.13	
S1.16		S1.14	Universe is 6-space
S1.17		S1.15	
S1.18		S1.19	Universe is 6-space
S1.19			

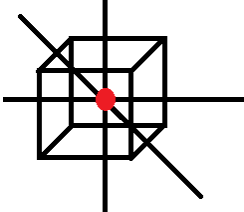
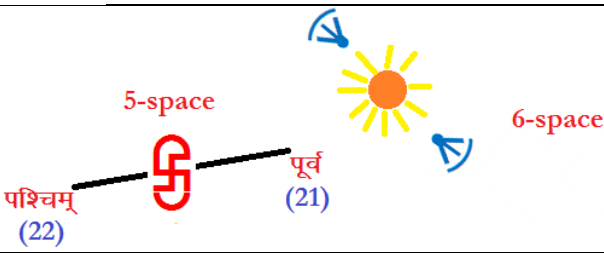
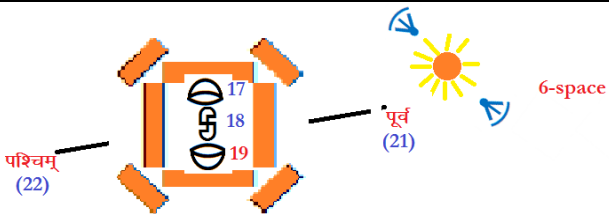
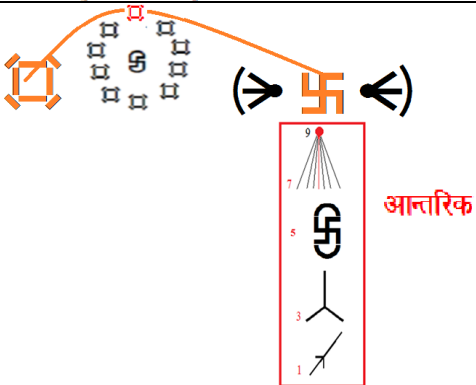
S1.20	
S1.21	
S1.22	
	

10 Spatial order formulation

S2.1	<h2 style="text-align: center;">Spatial order formulations</h2> $F = \frac{1}{2}, \frac{\frac{E}{2} - 2}{\sqrt{E}} \geq 2, \forall E \geq 2^7$
S2.2	<div style="display: flex; justify-content: space-around; align-items: center;"> 1 2 3 r M </div>  <div style="display: flex; justify-content: space-around; align-items: center;"> 2M-1 2M-2 2M-3 2M-r M </div>

11 Ten directional frame

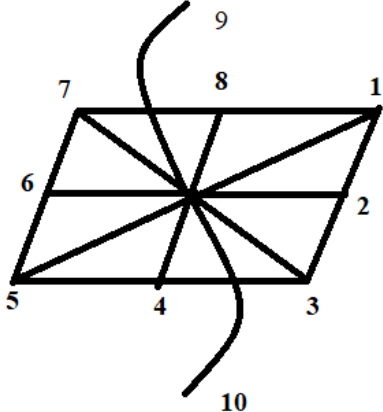
T3.1	<p>Ten directional frame</p> 
------	---

12 Chatuspeeth

C4.1

**Manifestation of Chatuspeeth
in transcendental space**

Paramvihom

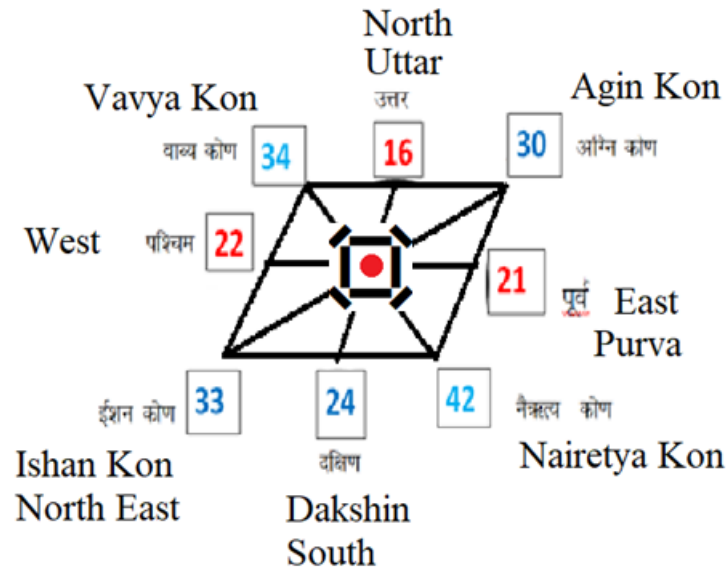

C4.2

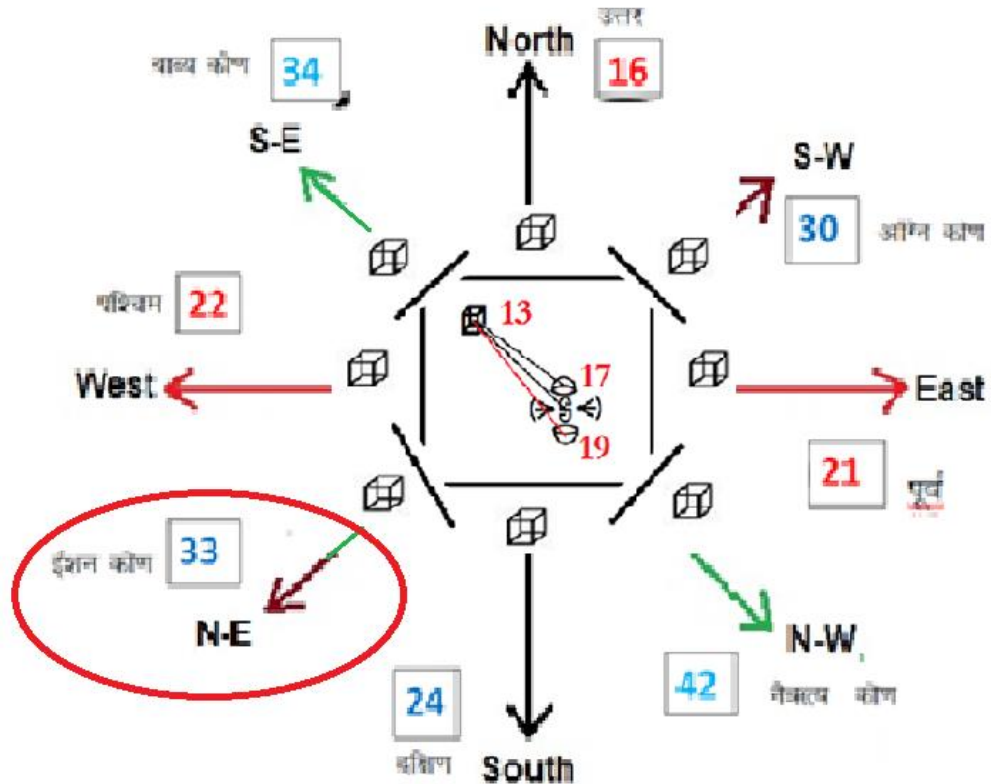

C4.3

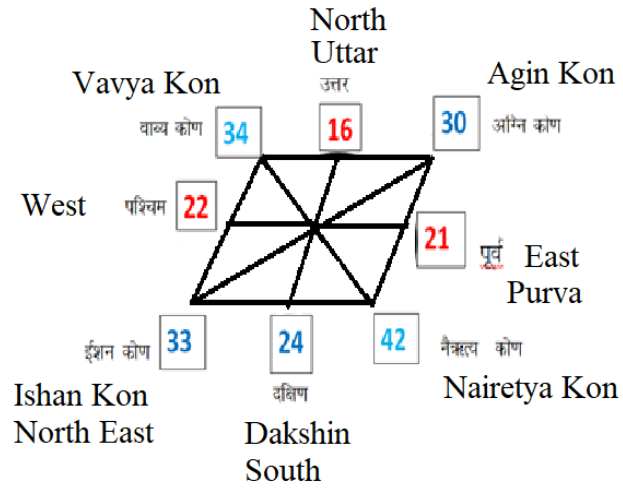

C4.4

Chatuspeeth
Ishan Kon axis

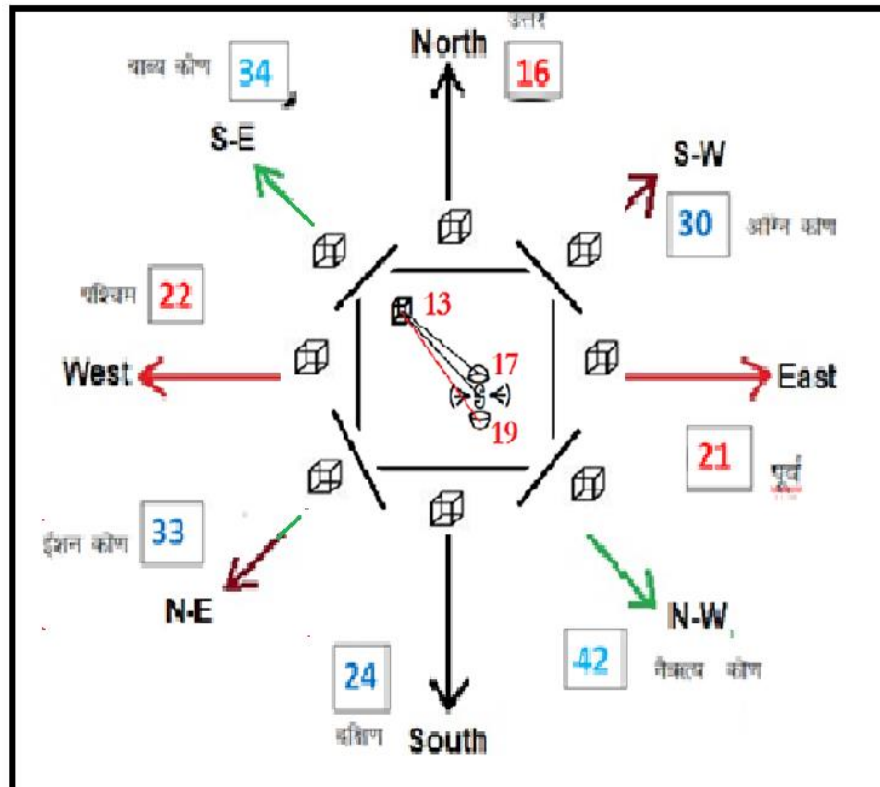
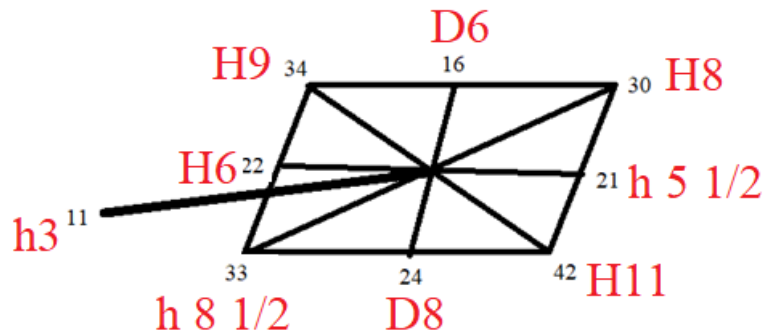

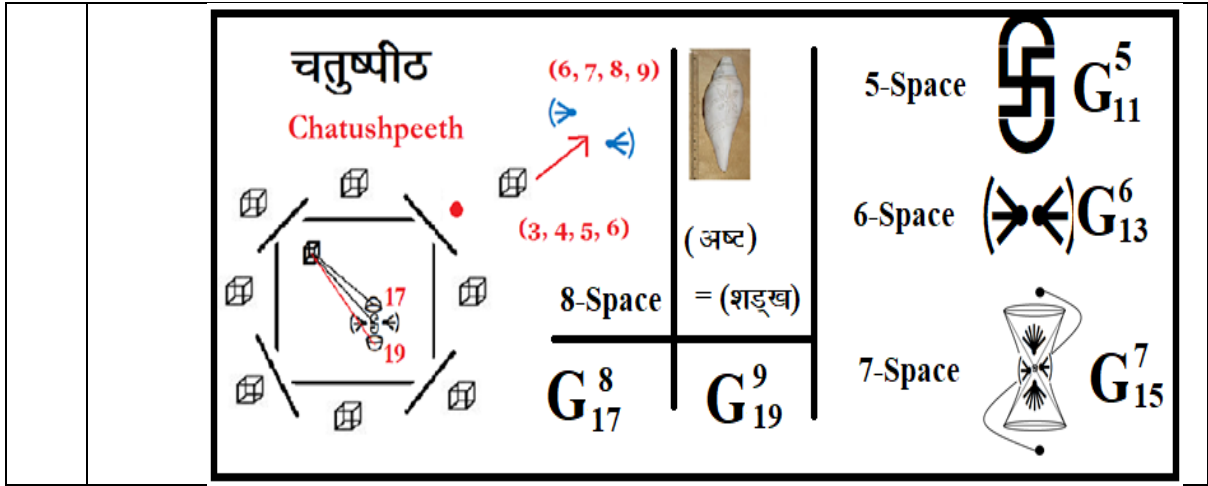

Chatuspeeth format of Transcendental content flow of values parallel with TCV value of Sutras

Table of Chatuspeeth format of Transcendental content flow of values parallel with TCV value of Sutras are shown in thick dark lines bulging out of the core circle of the chatuspeeth

Sutra 1	TCV	Chatuspeeth format	Flow values
1	75	<p>C4.5</p>	<p>75</p> <p>=33+42</p>
2	107	<p>C4.6</p>	<p>107</p> <p>=24+33 + 33+16</p>

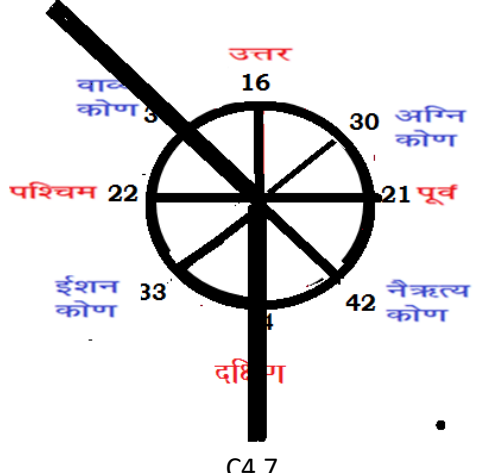
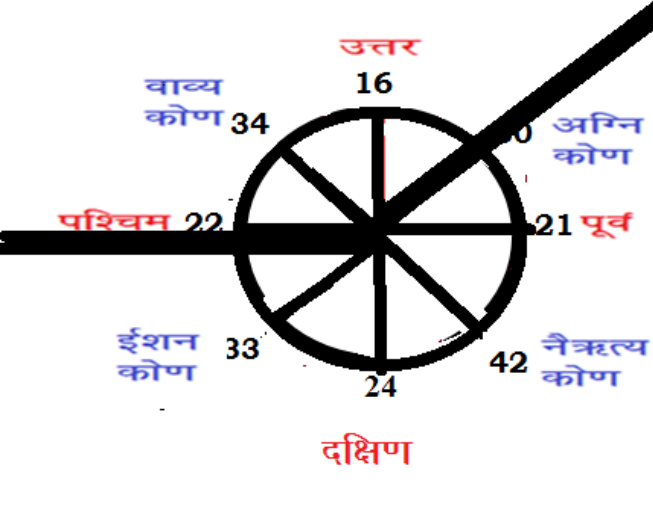
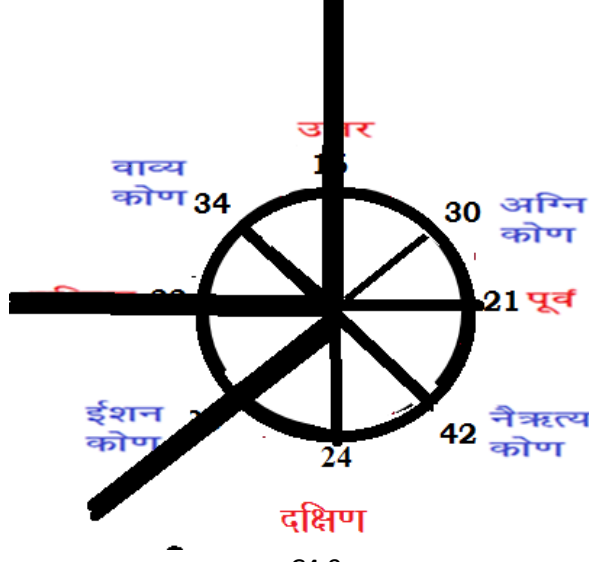
<p>3</p> <p>58</p>	 <p>C4.7</p>	<p>58</p> <p>=24+34</p>
<p>4</p> <p>52</p>	 <p>C4.8</p>	<p>52</p> <p>=22+30</p>
<p>5</p> <p>71</p>	 <p>C4.9</p>	<p>71</p> <p>=22+33+16</p>

<p>6</p> <p>76</p>	<p>C4.10</p>	<p>76</p> <p>=34+42</p>
<p>7</p> <p>91</p>	<p>C4.11</p>	<p>91</p> <p>=16+30</p> <p>+21+24</p>
<p>8</p> <p>68</p>	<p>C4.12</p>	<p>68</p> <p>=22+16+ 30</p>

<p>9</p>	<p>59</p>		<p>59 =34+1+24 FIRST JOINT</p>
<p>10</p>	<p>41</p>		<p>41 =16+1+24 SECOND JOINT</p>
<p>11</p>	<p>58</p>		<p>58 =16+42</p>

<p>12</p> <p>79</p>	<p>C4.16</p>	<p>79</p> <p>=16+30+33</p>
<p>13</p> <p>80</p>	<p>C4.17</p>	<p>80</p> <p>=24+22+34</p>
<p>14</p> <p>84</p>	<p>C4.18</p>	<p>84</p> <p>=16+21+ 24+22+1 THIRD JOINT</p>

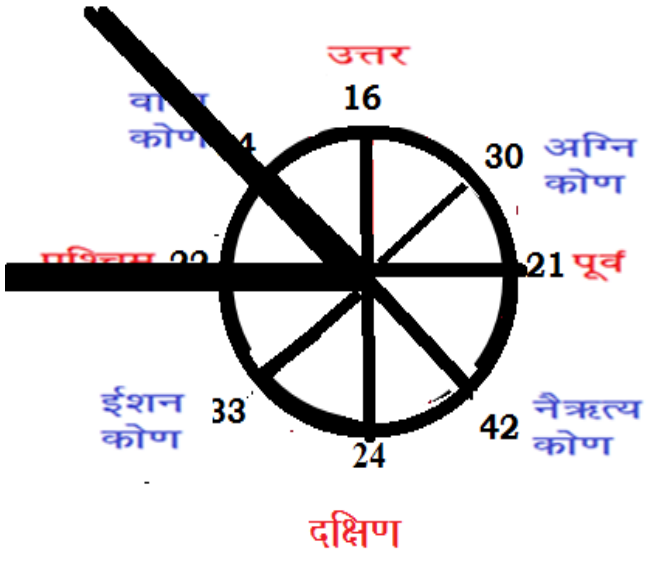
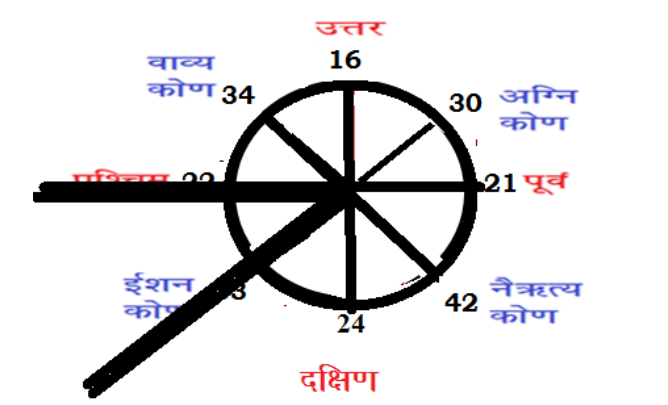
15	56	 <p style="text-align: center;">C4.19</p>	<p style="text-align: center;">56 =22+34</p>
16	55	 <p style="text-align: center;">C4.20</p>	<p style="text-align: center;">55 =33+22</p>

13 Chatuspeeth format of TCV values of Upsutras

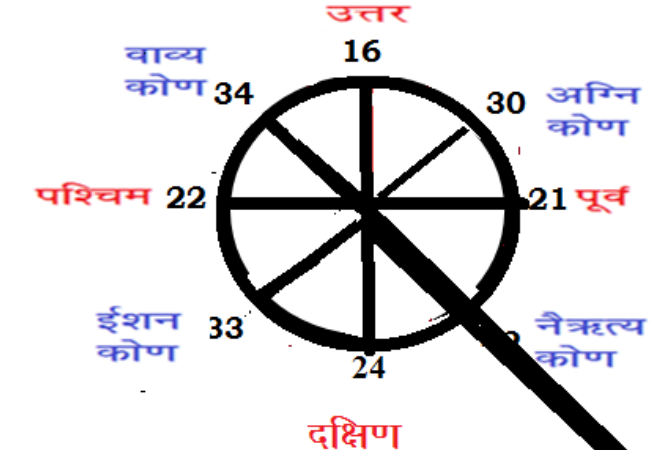
Upsutra 1	TCV	Chatuspeeth format	Elaboration Note
1	42	 <p style="text-align: center;">C4.19</p>	<p style="text-align: center;">42 =42</p>

		C4.21	
2	74		74 $=16+34+24$
		C4.22	
3	96		96 $=24+42+30$
		C4.23	
4	92		92 $=22+24+42$ $+30$
		C4.24	

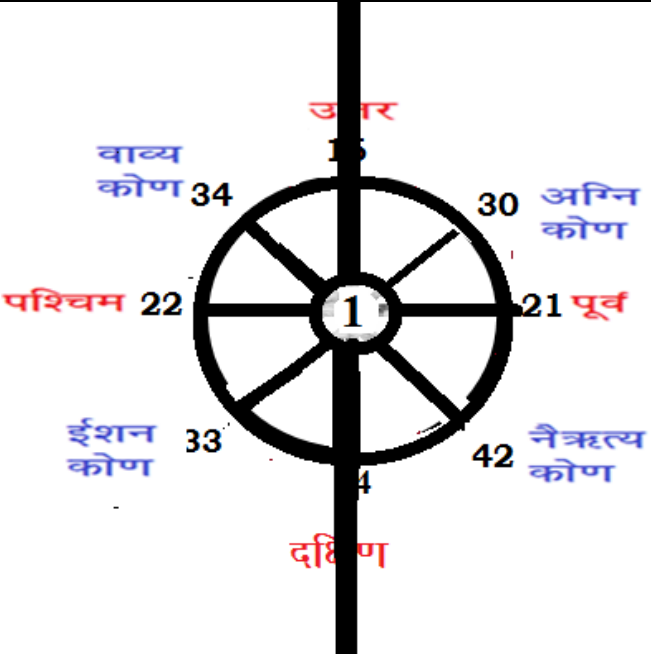
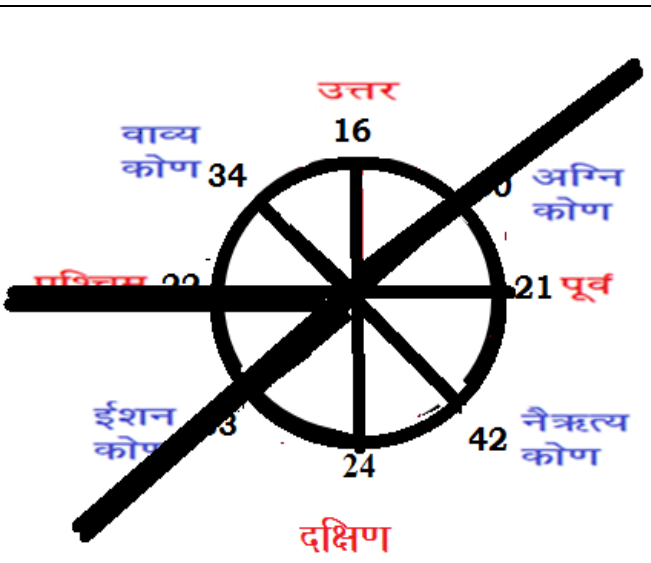
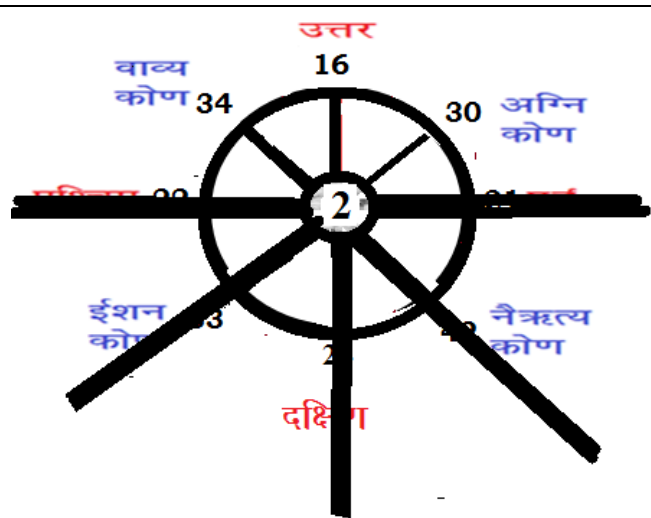
5	41	 <p style="text-align: center;">C4.25</p>	<p style="text-align: center;">41 =24+1+16 FIRST JOINT</p>
6	85	 <p style="text-align: center;">C4.26</p>	<p style="text-align: center;">85 =22+33 + 30</p>
7	144	 <p style="text-align: center;">C4.27</p>	<p style="text-align: center;">144 =22+33+24+ 42+21+2 SECOND JOINT OF DOUBLE CC</p>

<p>8</p>	<p>53</p>	<p>C4.28</p>	<p>53 =22+1+30 THIRD JOINT</p>
<p>9</p>	<p>40</p>	<p>C4.29</p>	<p>40 =16+24</p>
<p>10</p>	<p>56</p>	<p>C4.30</p>	<p>56 =34+22</p>

<p>11</p>	<p>73</p>	<p>C4.31</p>	<p>73 =16+33+24</p>
<p>12</p>	<p>44</p>	<p>C4.32</p>	<p>73 =22+1+21 FOURTH JOINT</p>
<p>13</p>	<p>112</p>	<p>Outer circle summation value 112 Inner circle summation value 222</p> <p>C4.33</p>	<p>112 Outer circle summation value 112</p>

14 Perfect number

Features	First perfect number	Second perfect number	Third perfect number	Fourth perfect number
Number	6	28	496	8128
Proper divisors	1, 2, 3			
Number of proper divisors	3	5	9	13
Biggest prime proper divisors				

15 Ten folds of formulations Surya

Formulation Surya सूर्य

1	2	3	4	5	6	7	8	9	10
1	2	3	12	0	72	38	42	90	192
1	3	6	18	18	90	128	170	260	452

F6.1

Formulation Nabhi नाभि

1	2	3	4	5	6	7	8	9	10
1	2	4	20	40	100	54	72	140	300
1	3	7	27	67	167	221	293	433	733

F6.2

Om Ita Ek Akshar Braham

ॐ इति एक अक्षर ब्रह्म

F6.2

4-space origin of 3-space

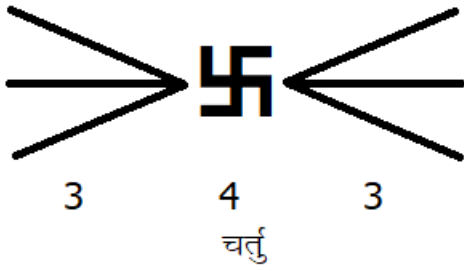

TCV (चर्तु)=12

43 + 4 = 47

43 + 12 = 55

अर्जुन विषाद योग

19 24 12

F6.3

16 13 versions of Hyper cube 6

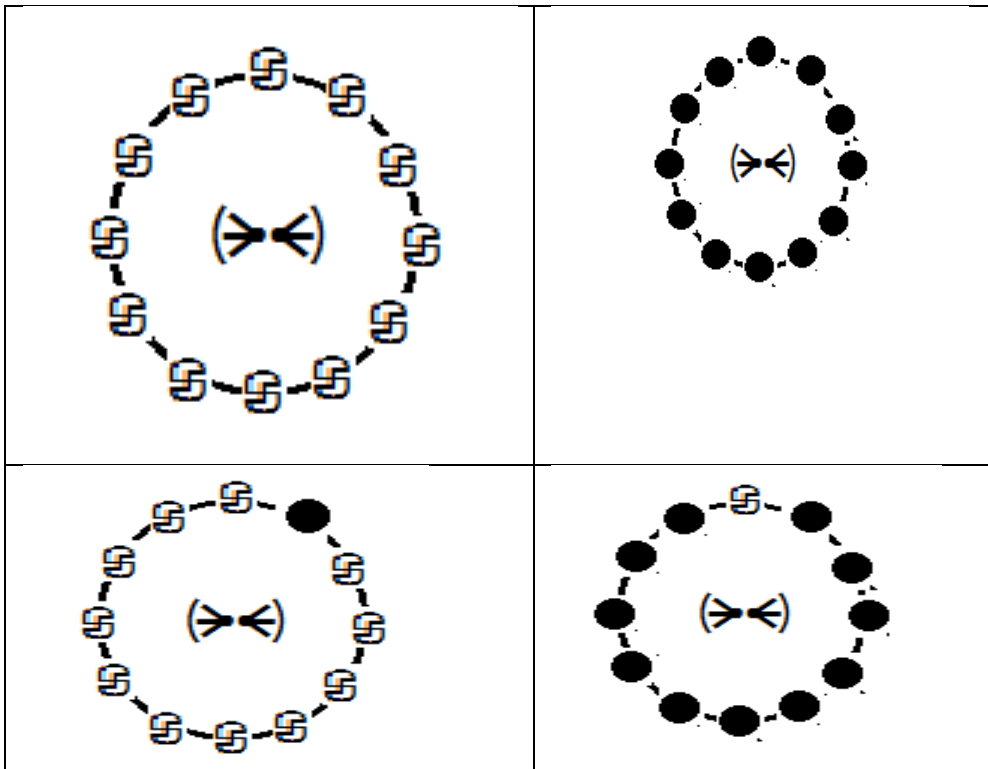

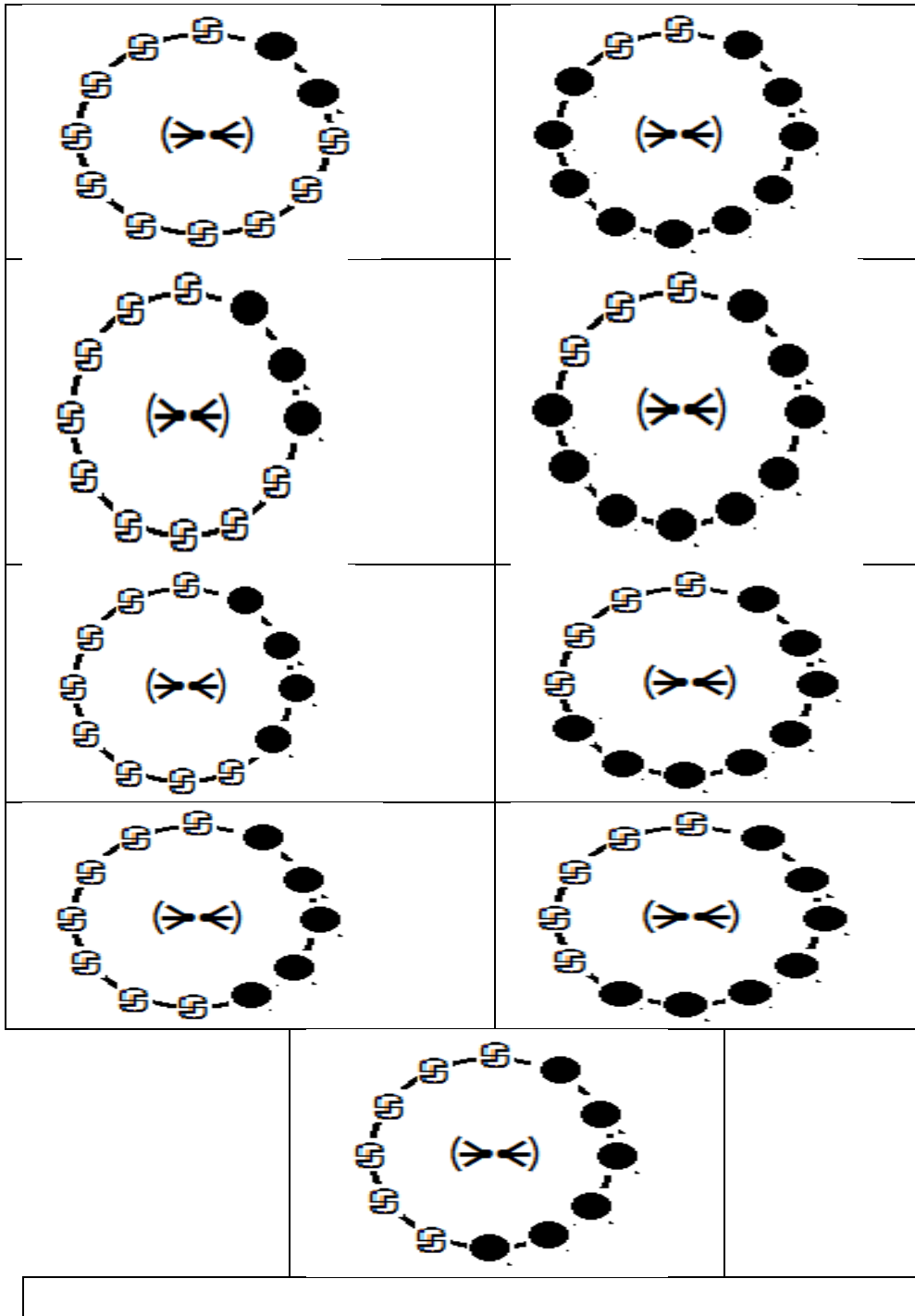

17 11 versions of Hyper cube 5



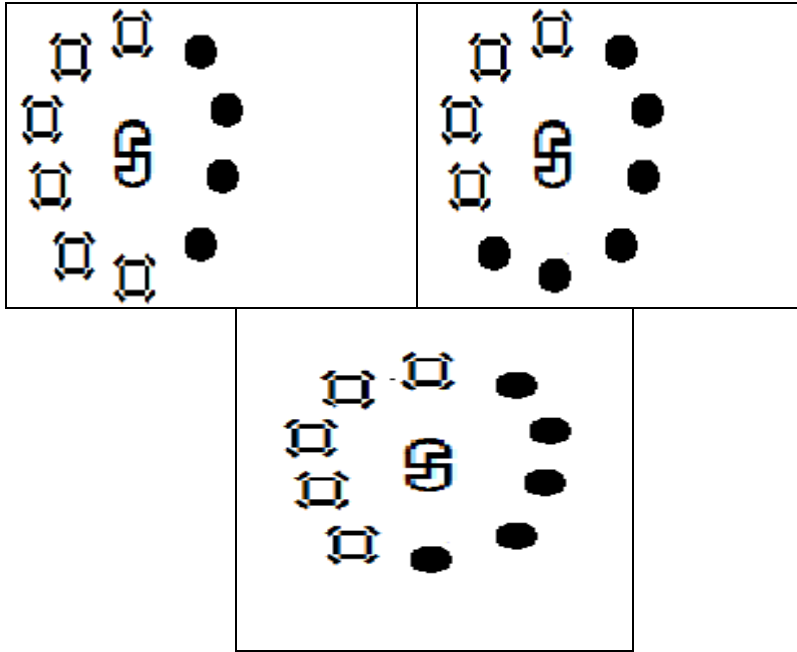

18 9 versions of Hyper cube 4

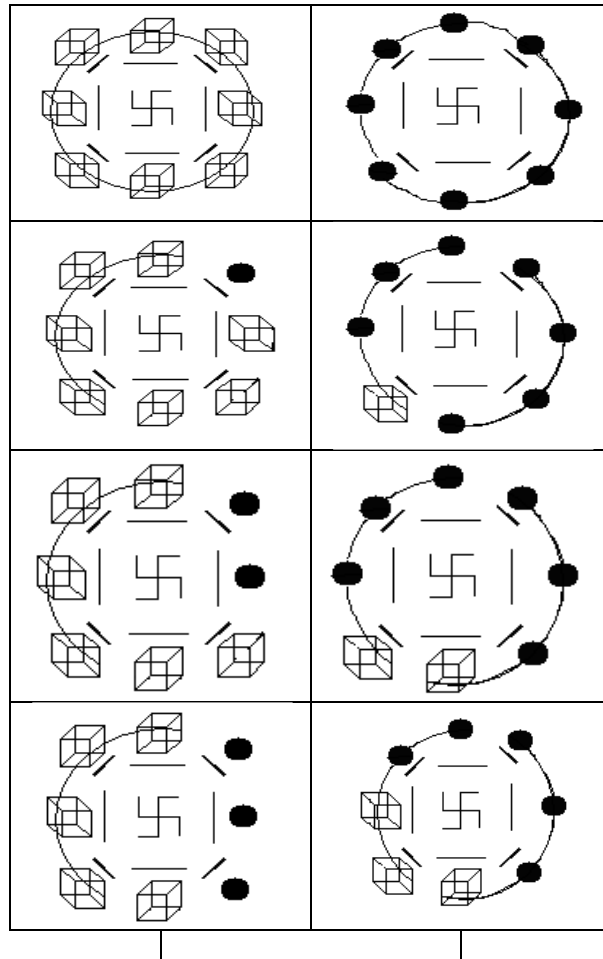

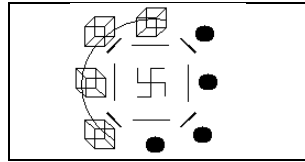

19

7 versions of Hyper cube 3

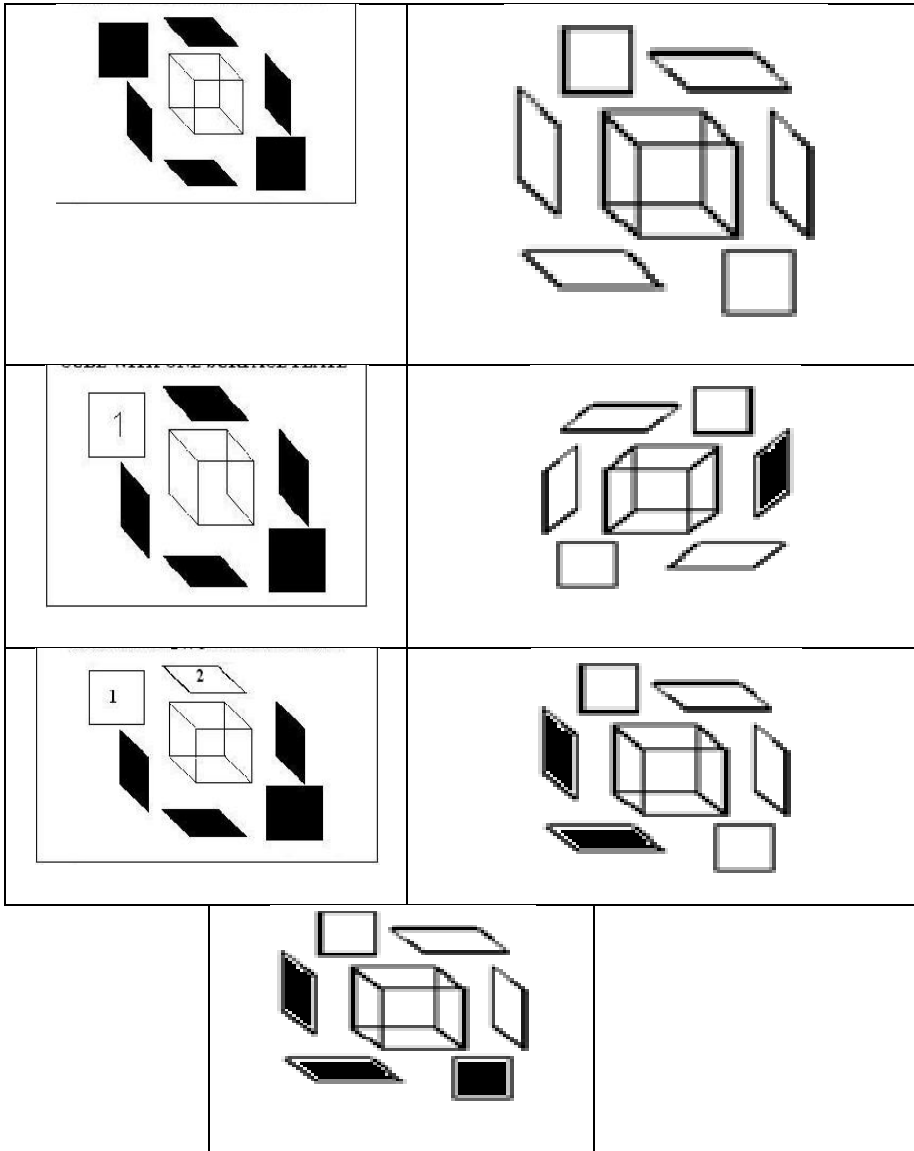

20 Hyper cube 1 to 6

HC1.1	<table border="1"> <tr> <th colspan="6">Hyper cubes 1 to 6</th> </tr> <tr> <td>1</td> <td>2</td> <td>3</td> <td>4</td> <td>5</td> <td>6</td> </tr> <tr> <td>—</td> <td>□</td> <td>⊠</td> <td>⊞</td> <td>⊚</td> <td>(><)</td> </tr> </table>	Hyper cubes 1 to 6						1	2	3	4	5	6	—	□	⊠	⊞	⊚	(><)	Hyper cube 1 to 7 Sathapatya Measuring rod
	Hyper cubes 1 to 6																			
1	2	3	4	5	6															
—	□	⊠	⊞	⊚	(><)															

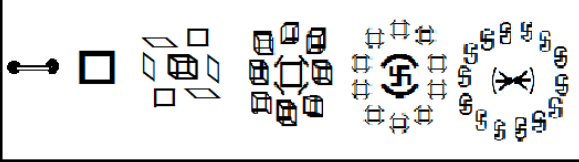
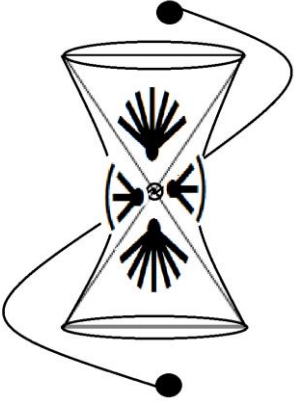
HC1.2	<table border="1" style="margin: auto;"> <tr> <th colspan="7">Hyper cubes 1 to 7</th> </tr> <tr> <td>1</td> <td>2</td> <td>3</td> <td>4</td> <td>5</td> <td>6</td> <td>7</td> </tr> <tr> <td style="text-align: center;">—</td> <td style="text-align: center;">□</td> <td style="text-align: center;">◻</td> <td style="text-align: center;">◻</td> <td style="text-align: center;">⊕</td> <td style="text-align: center;">⊗</td> <td style="text-align: center;">⊗</td> </tr> </table>	Hyper cubes 1 to 7							1	2	3	4	5	6	7	—	□	◻	◻	⊕	⊗	⊗	
Hyper cubes 1 to 7																							
1	2	3	4	5	6	7																	
—	□	◻	◻	⊕	⊗	⊗																	
HC1.3																							
HC1.4	<table border="1" style="margin: auto;"> <tr> <td style="text-align: center;">—</td> <td style="text-align: center;">□</td> <td style="text-align: center;">◻</td> <td style="text-align: center;">◻</td> <td style="text-align: center;">⊕</td> <td style="text-align: center;">⊗</td> <td style="text-align: center;">⊗</td> </tr> <tr> <td style="text-align: center;">A^1</td> <td style="text-align: center;">A^2</td> <td style="text-align: center;">A^3</td> <td style="text-align: center;">A^4</td> <td style="text-align: center;">A^5</td> <td style="text-align: center;">A^6</td> <td style="text-align: center;">A^7</td> </tr> <tr> <td style="text-align: center;">$2B^0$</td> <td style="text-align: center;">$4B^1$</td> <td style="text-align: center;">$6B^2$</td> <td style="text-align: center;">$8B^3$</td> <td style="text-align: center;">$10B^4$</td> <td style="text-align: center;">$12B^5$</td> <td style="text-align: center;">$14B^6$</td> </tr> </table>	—	□	◻	◻	⊕	⊗	⊗	A^1	A^2	A^3	A^4	A^5	A^6	A^7	$2B^0$	$4B^1$	$6B^2$	$8B^3$	$10B^4$	$12B^5$	$14B^6$	
—	□	◻	◻	⊕	⊗	⊗																	
A^1	A^2	A^3	A^4	A^5	A^6	A^7																	
$2B^0$	$4B^1$	$6B^2$	$8B^3$	$10B^4$	$12B^5$	$14B^6$																	
HC1.5	<table style="margin: auto;"> <tr> <td style="text-align: center;">1</td> <td style="text-align: center;">A^2</td> <td style="text-align: center;">A^3</td> <td style="text-align: center;">A^4</td> <td style="text-align: center;">A^5</td> <td style="text-align: center;">A^6</td> <td style="text-align: center;">A^7</td> </tr> <tr> <td style="text-align: center;">$2B^0$</td> <td style="text-align: center;">$4B^1$</td> <td style="text-align: center;">$6B^2$</td> <td style="text-align: center;">$8B^3$</td> <td style="text-align: center;">$10B^4$</td> <td style="text-align: center;">$10B^5$</td> <td style="text-align: center;">$14B^6$</td> </tr> <tr> <td style="text-align: center;">2</td> <td style="text-align: center;">8</td> <td style="text-align: center;">18</td> <td style="text-align: center;">32</td> <td style="text-align: center;">50</td> <td style="text-align: center;">72</td> <td style="text-align: center;">98</td> </tr> </table>	1	A^2	A^3	A^4	A^5	A^6	A^7	$2B^0$	$4B^1$	$6B^2$	$8B^3$	$10B^4$	$10B^5$	$14B^6$	2	8	18	32	50	72	98	
1	A^2	A^3	A^4	A^5	A^6	A^7																	
$2B^0$	$4B^1$	$6B^2$	$8B^3$	$10B^4$	$10B^5$	$14B^6$																	
2	8	18	32	50	72	98																	
HC1.6	<p style="text-align: center;"> $2+8+18+32+50+72+98 = 280$ (280, 281, 282, 283) Letters of Ganita Sutras 283 </p>																						
HC1.7		<p style="text-align: right;"> Damru Hyper cube 7 $A^7: 14B^6$ </p>																					





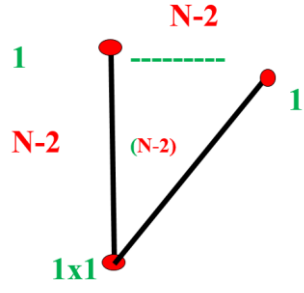
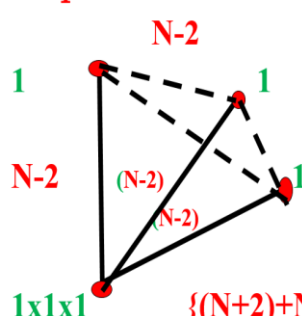
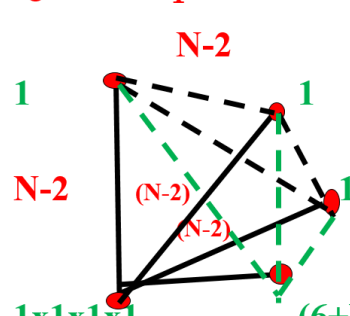

21 Eight directional frame

Edf 10.1		
Edf 10.2		
Edf 10.3		

22 Dimensions

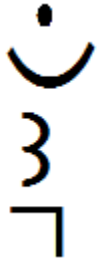
<p style="text-align: center; color: red; font-weight: bold;">Single dimension of order N</p>  <p style="text-align: center;">D12.1</p>	<p style="text-align: center; color: red; font-weight: bold;">Pair of dimensions of order N</p>  <p style="text-align: right; color: red; font-weight: bold;">$N+N-(N-2)$ $= N+2$</p> <p style="text-align: center;">D12.2</p>
<p style="text-align: center; color: red; font-weight: bold;">Triple dimensions</p>  <p style="text-align: right; color: red; font-weight: bold;">$\{(N+2)+N\}-2(N-2)$ $= 6$</p> <p style="text-align: center;">D12.3</p>	<p style="text-align: center; color: red; font-weight: bold;">Quadruple dimensions</p>  <p style="text-align: right; color: green; font-weight: bold;">$(6+N)-3(N-2)$ $= 12-2N$</p> <p style="text-align: center;">D12.4</p>

23 Om formulation

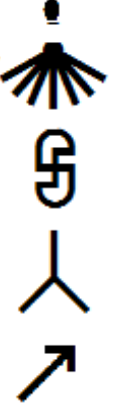
<p>1 Aum</p>			<p>1 2 3 4</p> 	<p>1 1 1 1</p> 
	<p>9 7</p> 	<p>9 7 3 1</p> <p>1 2 3 4</p> 	<p>9 7 3 1</p> 	<p>9 7 5 3 1</p> 

24 Bindu sarovar

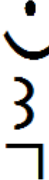
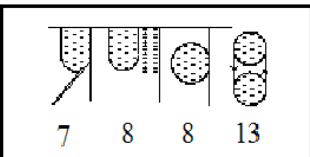
 <p>बिन्दुसरोवर अर्धमात्रा त्रिपुण्ड्रं स्वास्तिकपाद</p> <p>Bs14.1</p>	<p>Sama Parvah</p>  <p>Bs14.2</p>
---	---

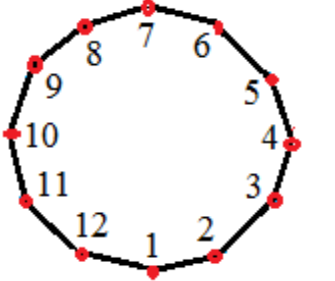
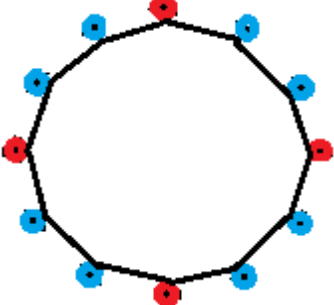
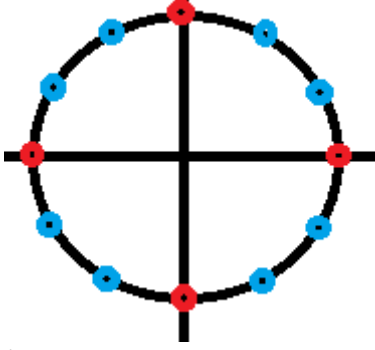

25 Polygon 12 figures

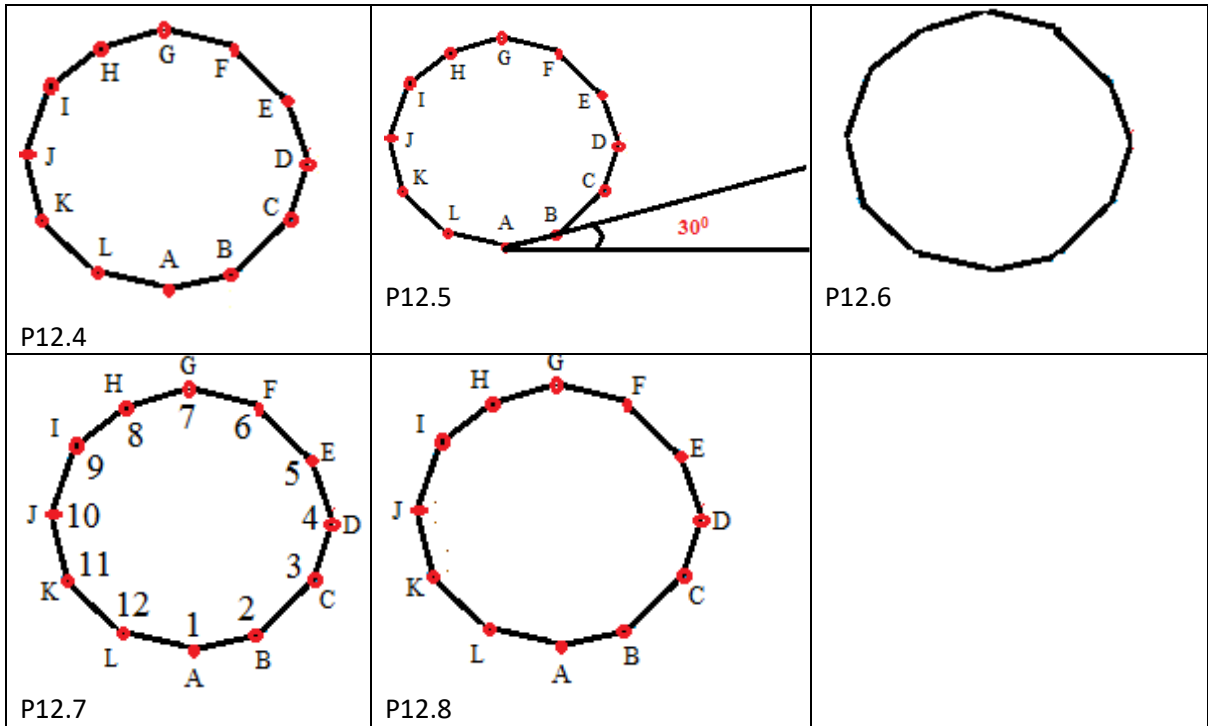
 <p>P12.1</p>	 <p>P12.2</p>	 <p>P12.3</p>
--	--	--



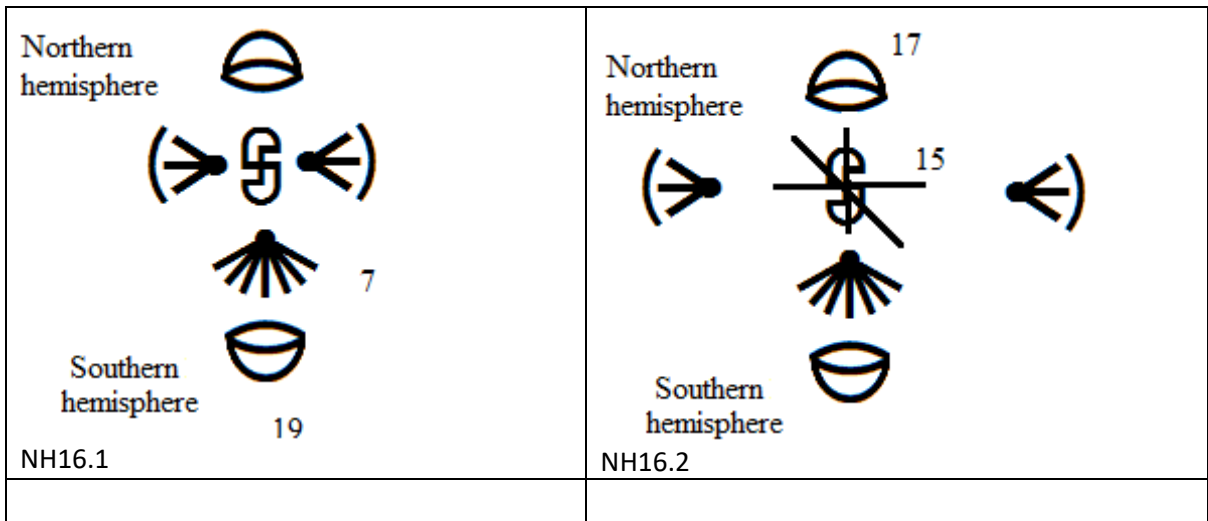

26 Northern hemisphere

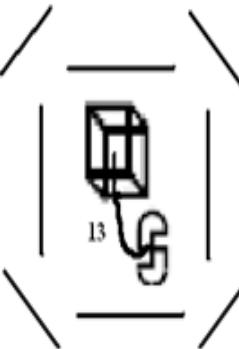



<p>Northern hemisphere</p>  <p>H5 18</p> <p>h5 19</p> <p>$= 18 + 19 = 37$</p> <p>Southern hemisphere</p>  <p>$37 \times 5 = 185$</p> <p>NH16.3</p>	 <p>$1+2+3+4+5$ 1 31 $1+2+3+4+5$ $31 \times 13 = 403$</p> <p>NH16.4</p>
--	--

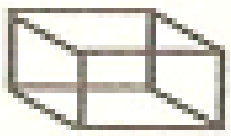
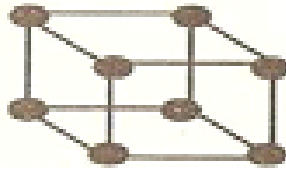
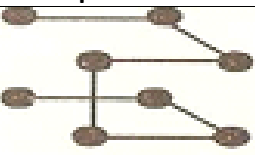
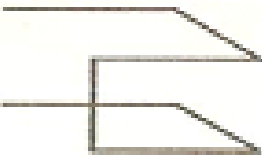

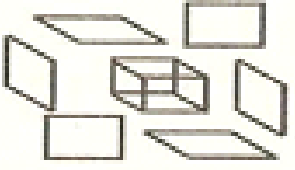
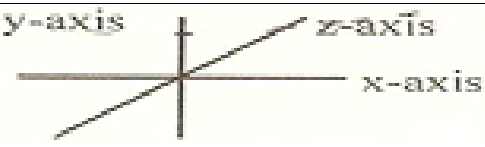
27 3, 4 and 5 spaces

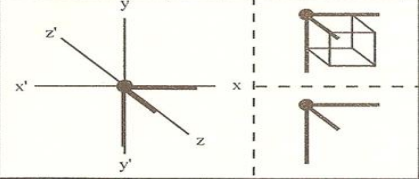
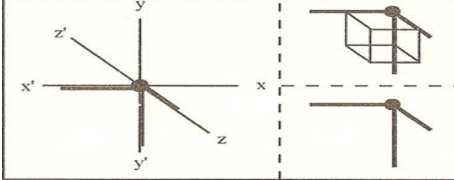
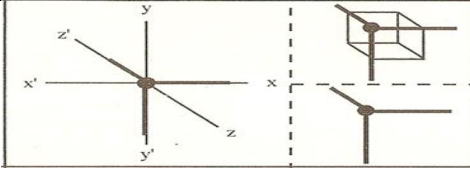
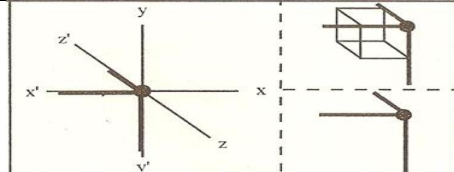
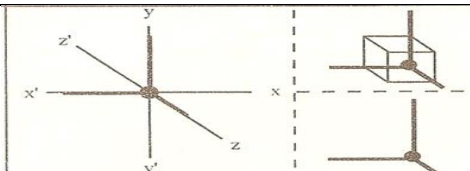
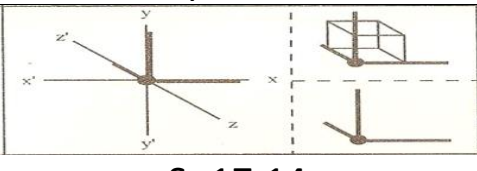
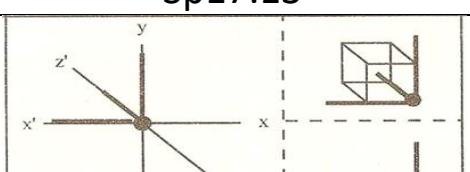
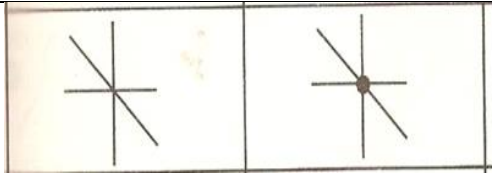
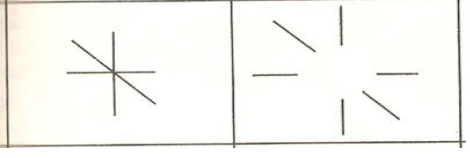
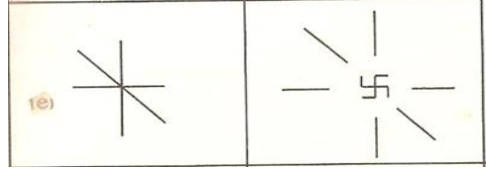
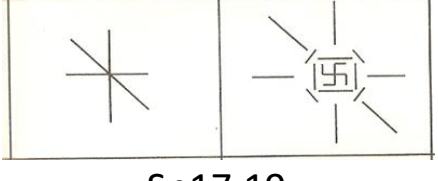
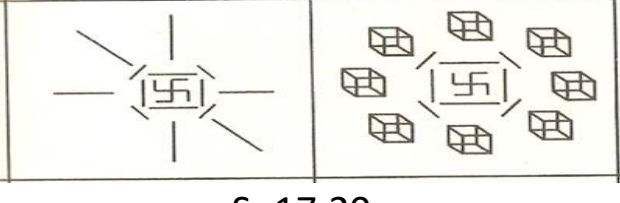
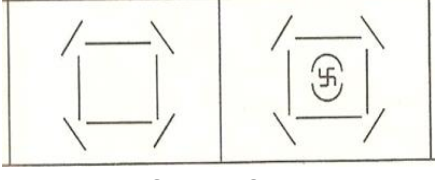
Sp17.1

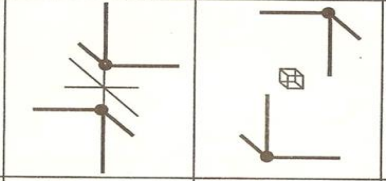
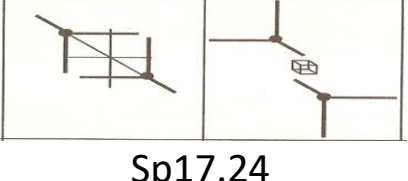
s. n o	Figure	Description
	 <p>Sp17.2</p>	 <p>Sp17.2</p>
	 <p>Sp17.3</p>	 <p>Sp17.4</p>
	 <p>Sp17.5</p>	 <p>Sp17.6</p>
	 <p>Sp17.7</p>	 <p>Sp17.8</p>

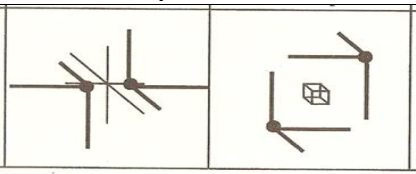
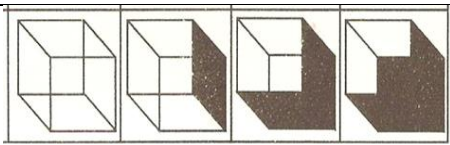
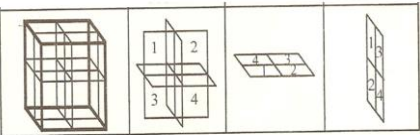
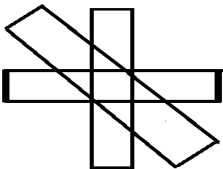
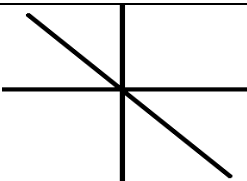
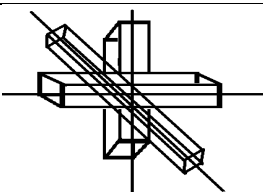
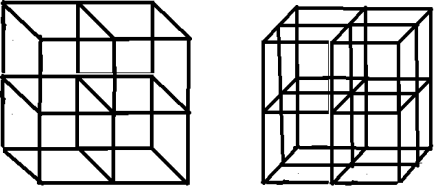
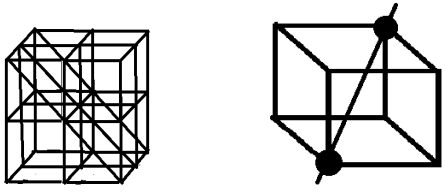
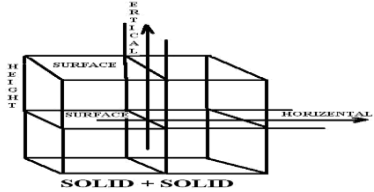
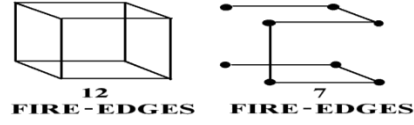
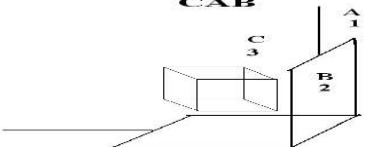
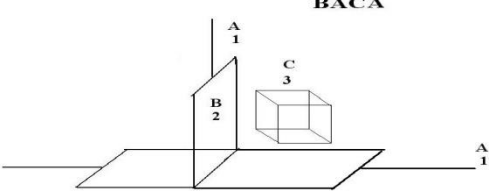
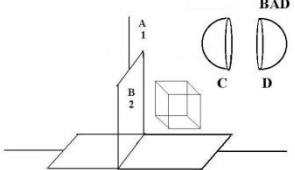
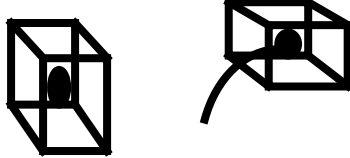
	 <p>Sp17.9</p>	 <p>Sp17.10</p>
6	 <p>Sp17.11</p>	 <p>Sp17.12</p>
7	 <p>Sp17.13</p>	 <p>Sp17.14</p>
8	 <p>Sp17.15</p>	 <p>Sp17.16</p>
9	 <p>Sp17.17</p>	 <p>Sp17.18</p>
10	 <p>Sp17.19</p>	 <p>Sp17.20</p>
11	 <p>Sp17.21</p>	 <p>Sp17.22</p>
12		 <p>Sp17.24</p>

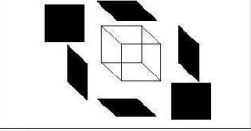
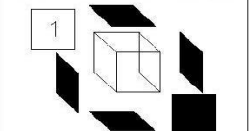
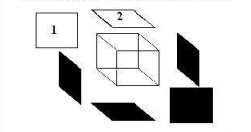
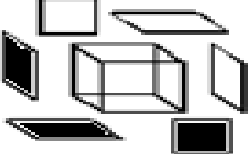
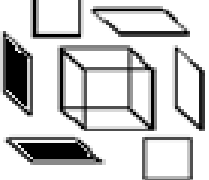
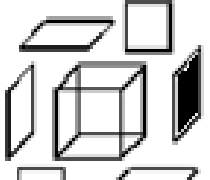
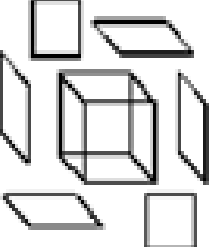
	Sp17.23	
13	 <p style="text-align: center;">Sp17.25</p>	 <p style="text-align: center;">Sp17.26</p>
14	 <p style="text-align: center;">Sp17.27</p>	 <p style="text-align: center;">Sp17.28</p>
15	 <p style="text-align: center;">Sp17.29</p>	 <p style="text-align: center;">Sp17.30</p>
20	 <p style="text-align: center;">Sp17.31</p>	 <p style="text-align: center;">Sp17.32</p>
22	 <p style="text-align: center;">Sp17.33</p>	 <p style="text-align: center;">Sp17.34</p>
23	<p style="text-align: center;">CAB</p>  <p style="text-align: center;">Sp17.35</p>	<p style="text-align: center;">BACA</p>  <p style="text-align: center;">Sp17.36</p>
24	 <p style="text-align: center;">Sp17.37</p>	 <p style="text-align: center;">Sp17.38</p>

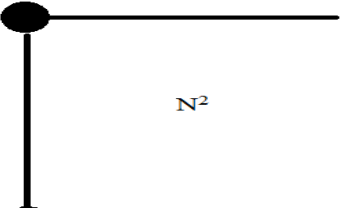
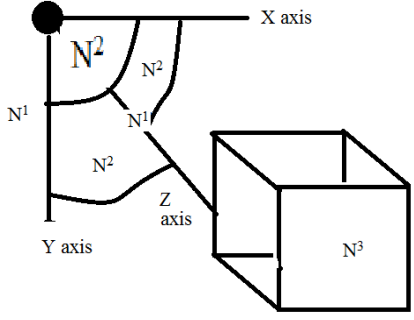
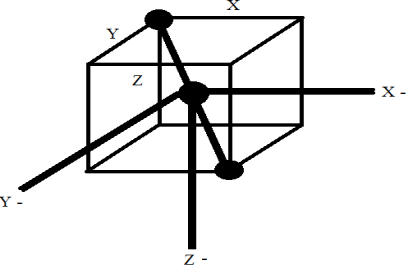
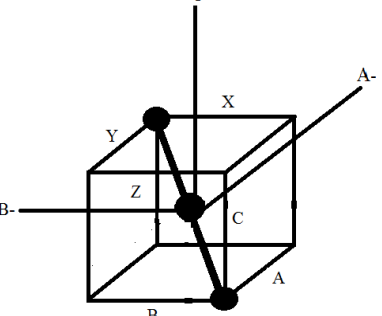
25	<p>SEVENTH GEOMETRY BODY OF 3-SPACE CUBE WITH ONE SURFACE PLATE</p>  <p>Sp17.39</p>	<p>SIXTH GEOMETRY BODY OF 3-SPACE CUBE WITH ONE SURFACE PLATE</p>  <p>Sp17.40</p>
26	<p>FIFTH GEOMETRY BODY OF 3-SPACE CUBE WITH TWO SURFACE PLATE</p>  <p>Sp17.41</p>	 <p>Sp17.42</p>
27	 <p>Sp17.43</p>	 <p>Sp17.44</p>
28	 <p>Sp17.45</p>	<p>N^0 N^1</p>  <p>Sp17.46</p>
29	<p>N^0 N^1</p>  <p>Sp17.47</p>	<p>N^0 N^1</p>  <p>Sp17.48</p>
30	 <p>Sp17.49</p>	

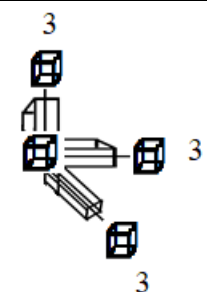
		Sp17.50
31	 <p>3 3 3 Sp17.51</p>	

28 Dimensional split spectrum format

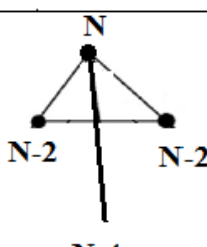

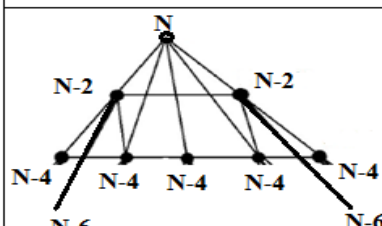

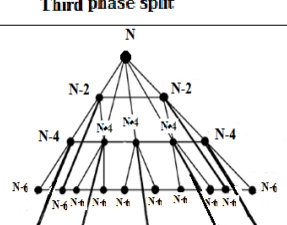

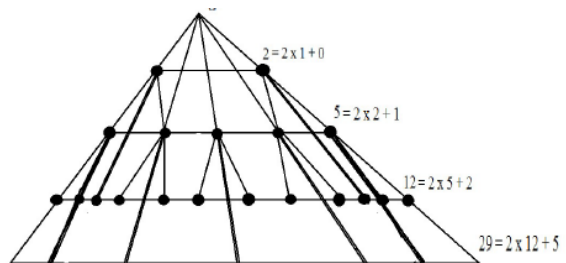





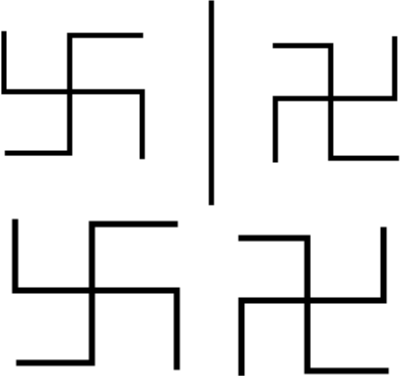

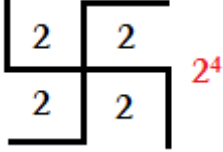

First phase split	domain entities
	1 2

















Second phase split	Domain entities	Relationship with previous and previous to previous split phase
	5	Previous phase domain entities = 2 previous to previous phase domain entities = 2 $5 = 2 \times 2 + 1$









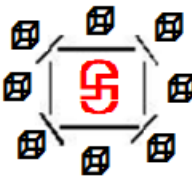

Third phase split	Domain entities	Sequential Relationship with previous and previous to previous split phase
	12	Previous phase domain entities = 5 previous to previous phase domain entities = 2 $12 = 2 \times 5 + 2$







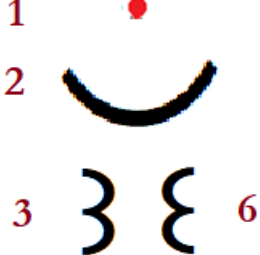

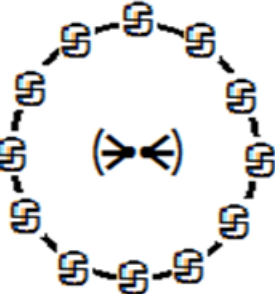
29 Vedic Alphabet (VA)

Sr	.					
1	a	 VA1.1	1 9	I	 VA1.2	 VA1.3
2	b	 VA1.4	2 0	J	 VA1.5	 VA1.6
3	c	 VA1.7	2 1	K	 VA1.8	Northern Hemisphere
4	d	 VA1.9	2 2	L	 VA1.10	
5	e	 VA1.11 1	2 3	M	 VA1.12	
6	f	 VA1.13 3	2 4	N	 VA1.14	 7-space
7	g	 VA1.15 5	2 5	O	 VA1.16	

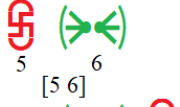
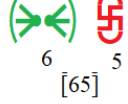
8	h	 VA1.1 7	2 6	P	 VA1.18	
9	i	 VA1.1 9	2 7	Q	 VA1.20	 VA1.21
1 0	j	 VA1.2 2	2 8	R	 VA1.23	 VA1.24
1 1	A	 VA1.2 5	2 9	S	 VA1.25	Transcendental seal at origin seat of 4-space  VA1.26
1 2	B	 VA1.2 7	3 0	T	 VA1.28	Transcendental space Paramvihom (परमवियोम्) TCV (परमवियोम्)=44  4 0 4 VA1.29
1 3	C	 VA1.3 0	3 1	U	 VA1.31	Hyper cube 5 (2, 3, 4, 5)  VA1.32

1 4	D	 VA1.3 3	3 2	V	 VA1.34	Transcendence of origin Transcendence spectrum  4 + 5 + 4 VA1.35
1 5	E	 VA1.3 6	3 3	W	 VA1.37	Transcendental space of self referral features Paramvihom (परमवियोम्) TCV (परमवियोम्)=44  4 0 4 Self referral features  5 6 5 VA1.38
1 6	F	 VA1.3 9	3 4	X	 VA1.40	 1 2 3 6 VA1.41
1 7	G	 VA1.4 2	3 5	Y	 VA1.43	Hyper Cube 6  A ⁶ :12B ⁵ 12x5= 60 VA1.44

1 8	H	 VA1.4 5	3 6	Z	 VA1.46	
					<div data-bbox="679 443 935 842" style="border: 1px solid black; padding: 5px;"> <p>Transcendental space of self referral features</p> <p>Self referral features</p>  <hr/>   </div>	<div data-bbox="1023 421 1321 819" style="border: 1px solid black; padding: 5px;"> <p>Transcendence of origin</p> <p>Transcendence spectrum</p>  <hr/>  <p>[45]</p>  <p>[54]</p> </div> <p style="text-align: center;">VA1.48</p>

30 Divya Ganga Parvah 1

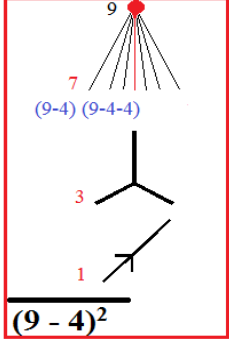
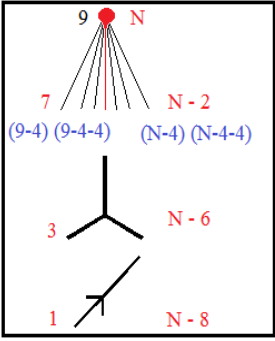
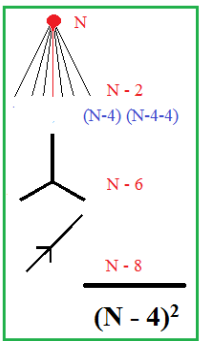
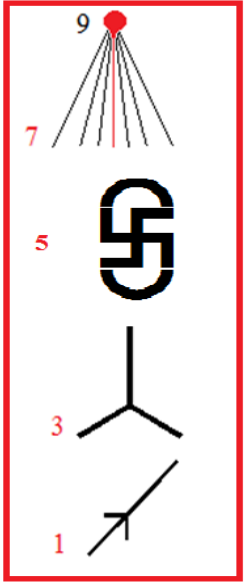
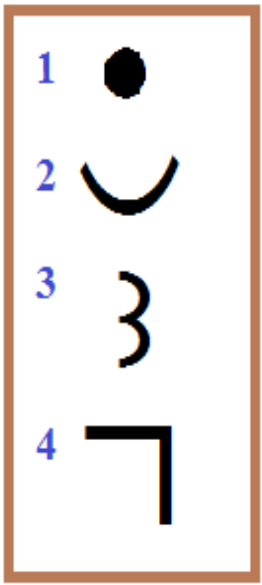
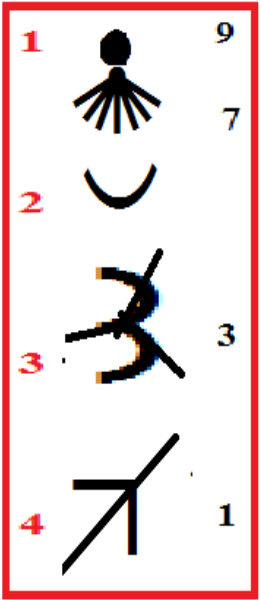
 <p>DGP1.1</p>	 <p>DGP1.2</p>	 <p>DGP1.3</p>
 <p>DGP1.4</p>	 <p>DGP1.5</p>	 <p>DGP1.6</p>

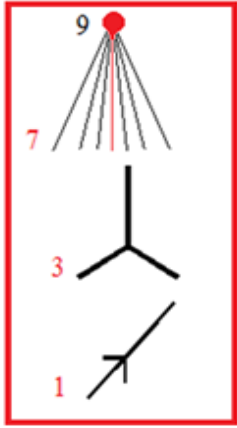

DGP1.7

- 1 ● Bindu Saraover
- 2 ⤿ Ardh Matra
- 3 } Tripundram
- 4 ⊔ Swastik Pada

DGP1.8
N - space content as
Divya Ganga Parvah
is of flow value $(n-4)^2$

- 1 ● (N)
- 2 ⤿ (N - 2)
- 3 } (N - 4) x (N - 8)
- 4 ⊔ (N - 8)

DGP1.9

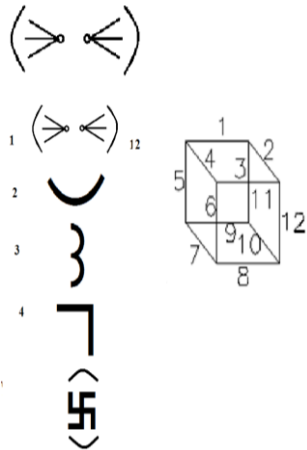

DGP1.10

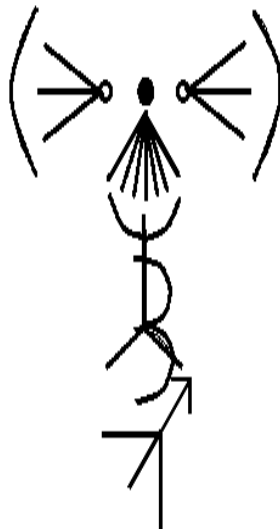

DGP1.11

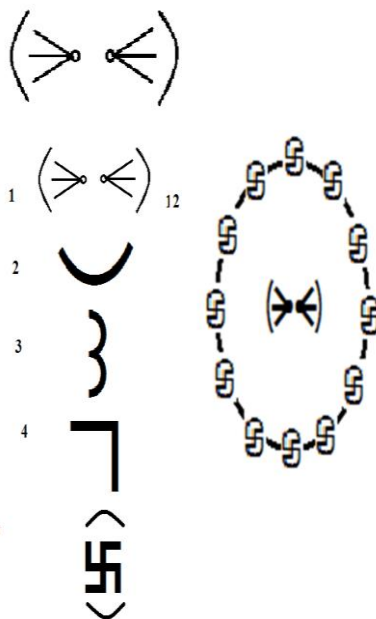

DGP1.11

Divya Ganga Parvah

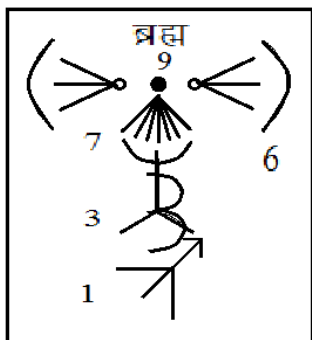

DGP1.12

- बिन्दु सरोवर
(Bindu sarovar) ●
- अर्धमात्रा
(Ardh matra) ⤿
- त्रिपुण्ड्र
(Tripudram) }
- स्वास्तिक पाद
(Swastik Pada) ⊔

DGP1.13

31 Transcendental cavity 1

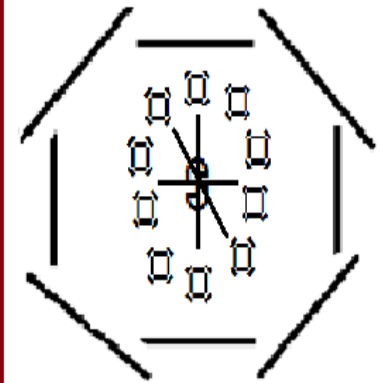
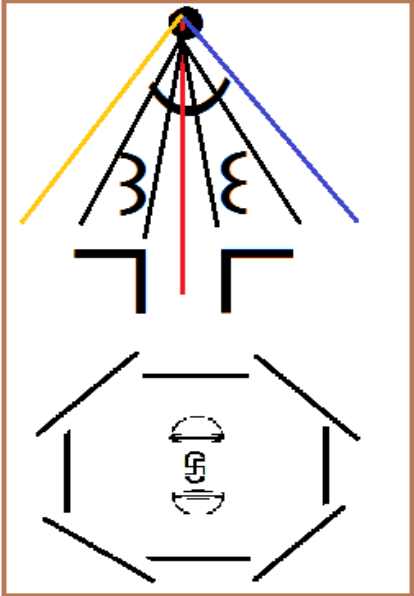
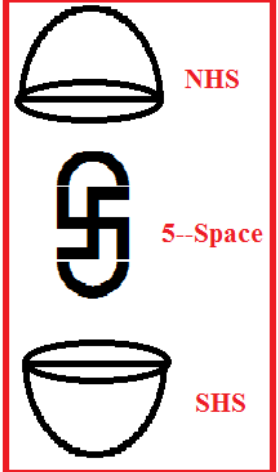
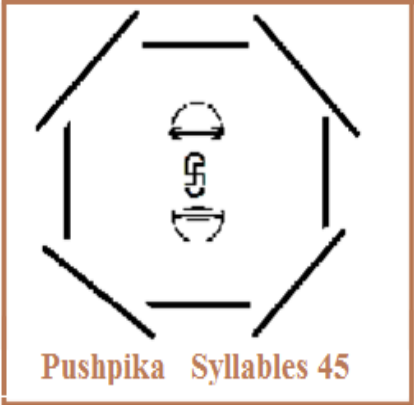
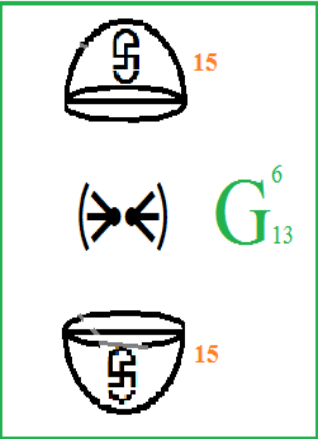
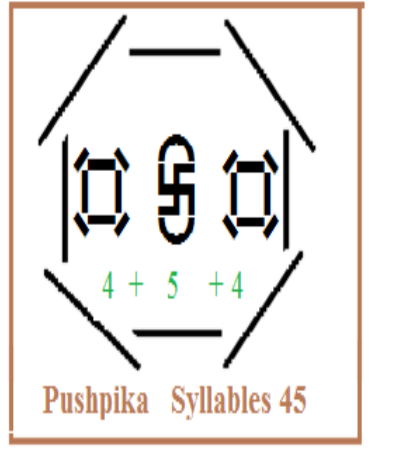
<p>Transcendental cavity $10 \times 4 = 40$ coordinates three dimensions</p>  <p>Pushpika Syllables 45</p>		
 <p>TC10.1</p>	<p>TC10.2</p>  <p>Pushpika Syllables 45</p>	
 <p>TC10.3</p>	<p>TC10.4</p>  <p>Pushpika Syllables 45</p>	

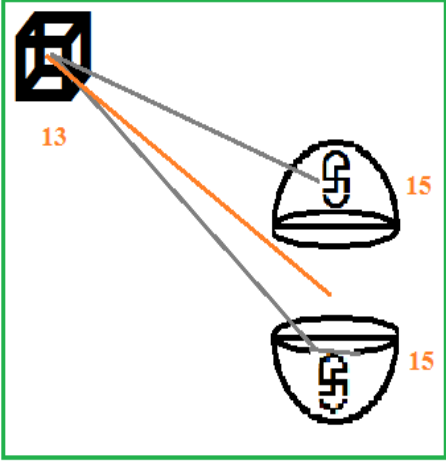
 <p style="text-align: center;">TC10.7</p>	TC10.6		
---	--------	--	--

32 Place value systems

Upper part of 9 x 11 grid
Mirror line 11, 22, 33, 44

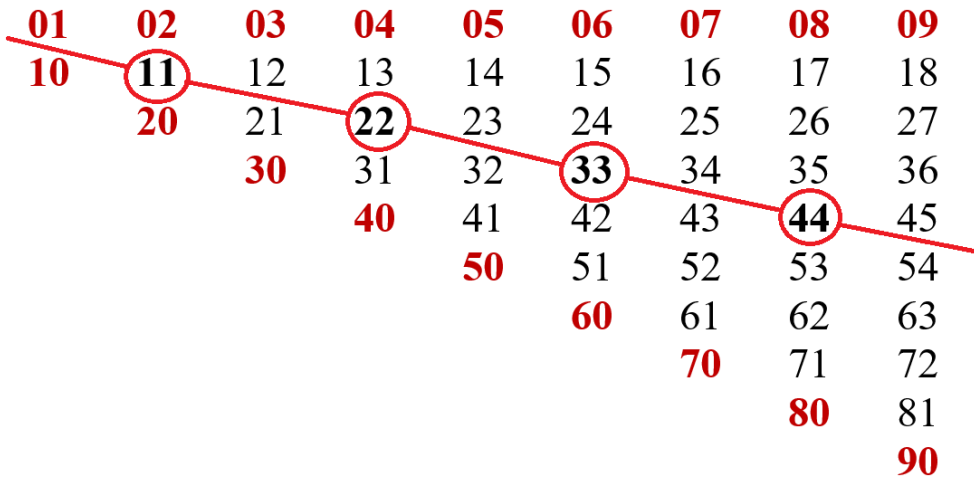

Lower part of 9 x 11 grid

Mirror line 55, 66, 77, 88, 99

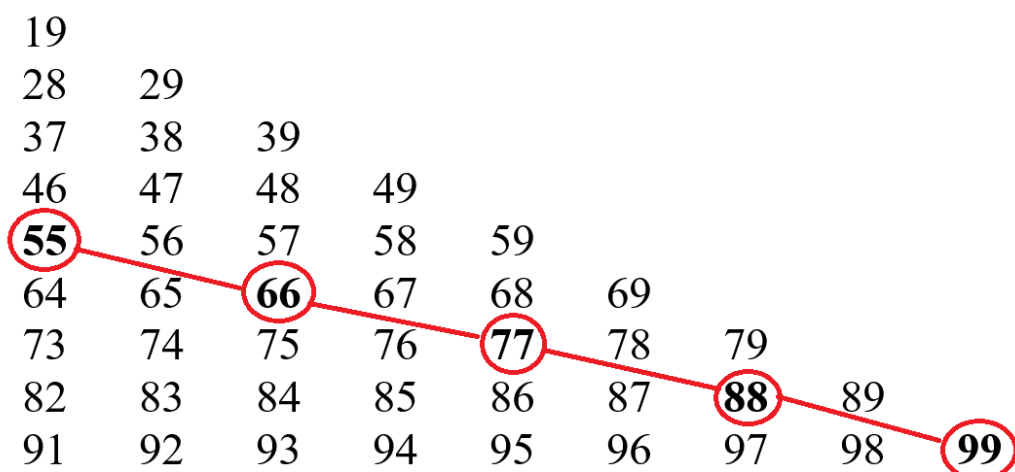

Upper part of 9 x 11 grid

01	02	03	04	05	06	07	08	09
10	11	12	13	14	15	16	17	18
	20	21	22	23	24	25	26	27
		30	31	32	33	34	35	36
			40	41	42	43	44	45
				50	51	52	53	54
					60	61	62	63
						70	71	72
							80	81
								90

9 x 11 grid

01	02	03	04	05	06	07	08	09
10	11	12	13	14	15	16	17	18
19	20	21	22	23	24	25	26	27
28	29	30	31	32	33	34	35	36
37	38	39	40	41	42	43	44	45
46	47	48	49	50	51	52	53	54
55	56	57	58	59	60	61	62	63
64	65	66	67	68	69	70	71	72
73	74	75	76	77	78	79	80	81

82	83	84	85	86	87	88	89	90
91	92	93	94	95	96	97	98	99

Lower part of 9 x 11 grid

19								
28	29							
37	38	39						
46	47	48	49					
55	56	57	58	59				
64	65	66	67	68	69			
73	74	75	76	77	78	79		
82	83	84	85	86	87	88	89	
91	92	93	94	95	96	97	98	99



Lower part of 9 x 11 grid
Mirror line 55, 66, 77, 88, 99

19								
28	29							
37	38	39						
46	47	48	49					
55	56	57	58	59				
64	65	66	67	68	69			
73	74	75	76	77	78	79		
82	83	84	85	86	87	88	89	
91	92	93	94	95	96	97	98	99

<p>5 x 7 grid</p>	<p>Double digit numbers</p> <table border="1"> <tr><td>01</td><td>02</td><td>03</td><td>04</td></tr> <tr><td></td><td>05</td><td></td><td></td></tr> <tr><td>10</td><td>11</td><td>12</td><td>13</td></tr> <tr><td></td><td>14</td><td></td><td></td></tr> <tr><td>15</td><td>20</td><td>21</td><td>22</td></tr> <tr><td></td><td>23</td><td></td><td></td></tr> <tr><td>24</td><td>25</td><td>30</td><td>31</td></tr> <tr><td></td><td>32</td><td></td><td></td></tr> <tr><td>33</td><td>34</td><td>35</td><td>40</td></tr> <tr><td></td><td>41</td><td></td><td></td></tr> <tr><td>42</td><td>43</td><td>44</td><td>45</td></tr> <tr><td></td><td>50</td><td></td><td></td></tr> <tr><td>51</td><td>52</td><td>53</td><td>54</td></tr> <tr><td></td><td>55</td><td>100</td><td></td></tr> </table>	01	02	03	04		05			10	11	12	13		14			15	20	21	22		23			24	25	30	31		32			33	34	35	40		41			42	43	44	45		50			51	52	53	54		55	100		<p>Grid 5 x 7</p>
01	02	03	04																																																							
	05																																																									
10	11	12	13																																																							
	14																																																									
15	20	21	22																																																							
	23																																																									
24	25	30	31																																																							
	32																																																									
33	34	35	40																																																							
	41																																																									
42	43	44	45																																																							
	50																																																									
51	52	53	54																																																							
	55	100																																																								

<p>6 x 8 grid</p>	<p>Grid 6 x 8</p>
<p>(N-1) x (N+1) grid</p>	<p>7 place value system</p>

<p>0</p>	<p>1</p>	<p>Hyper cube 2</p>		<p>0+1+2+3=6</p>	<p>4 x 4 grid</p>
<p>2</p>	<p>3</p>			<p>1+2+3+4=10</p>	

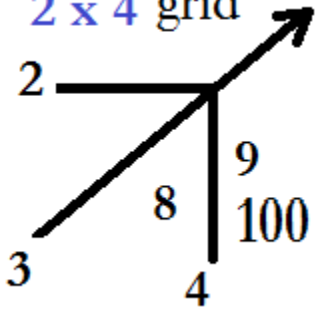
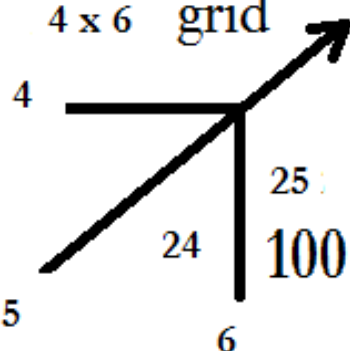
<p>1 2 3 4</p> <p>2 3 4 5</p> <p>3 4 5 6</p>	<p>Hyper cube 3</p> <p>Hyper cube 4</p> <p>Hyper cube 5</p>	 	<p>$2+3+4+5=14$</p> <p>$3+4+5+6=18$</p>	
<p>2 x 4 grid</p> 	<p>Double digit numbers</p> <p>00 02</p> <p>10 11</p> <p>12 20</p> <p>21 22 100</p>	<p>Grid 2 x 4</p>		
<p>4 x 6 grid</p> 				

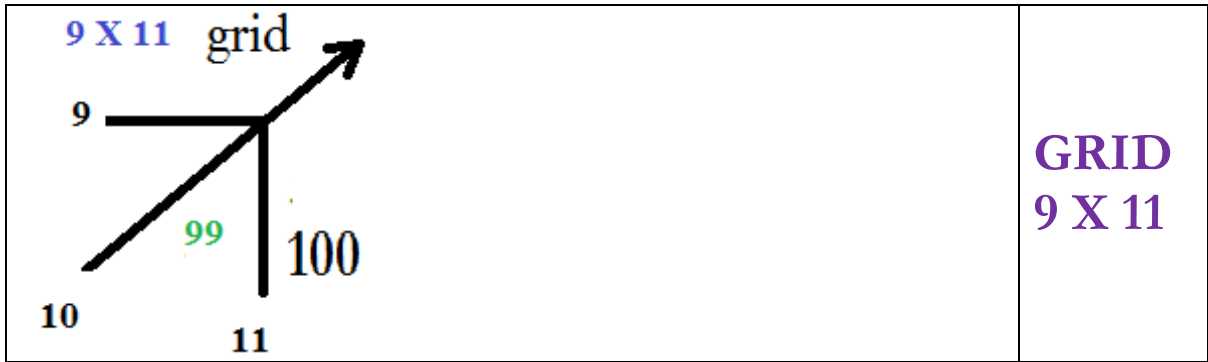

33 Separation plate of 8 octants

Central plate

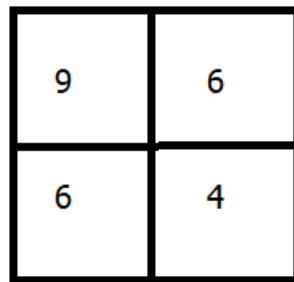

$9 \times 3 = 27$	$6 \times 3 = 18$	75
$6 \times 3 = 18$	$4 \times 3 = 12$	

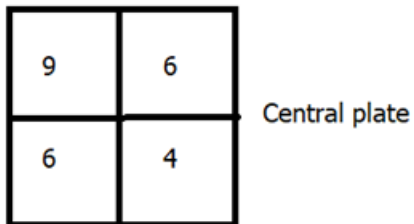

$9 \times 2 = 18$	$6 \times 2 = 12$
$6 \times 2 = 12$	$4 \times 2 = 8$

34 Half unit hyper cube

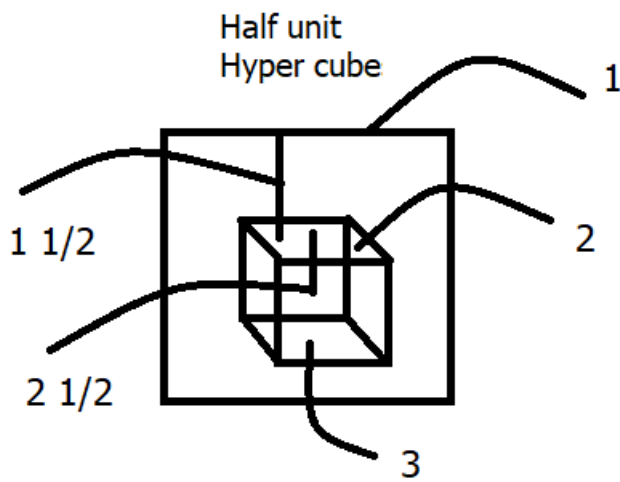

35 Param Vihom (Transcendental space)

Linear order

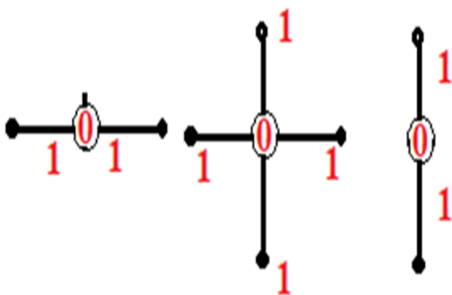

Thirteen 13 geometries of 6-space

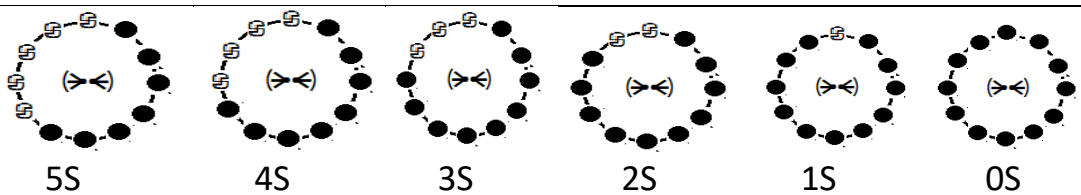
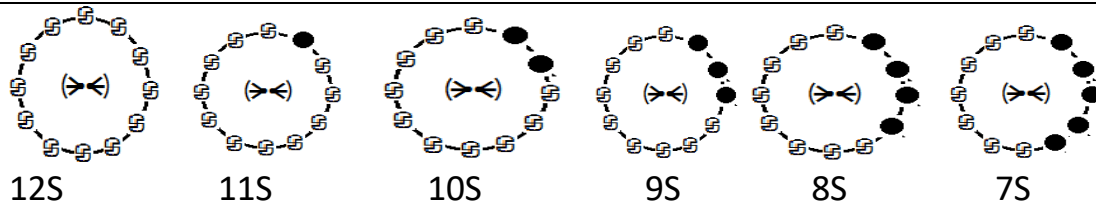

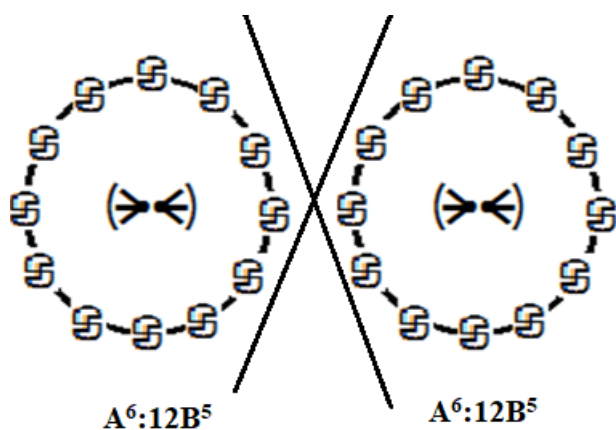

36 11 geometries of 5-space

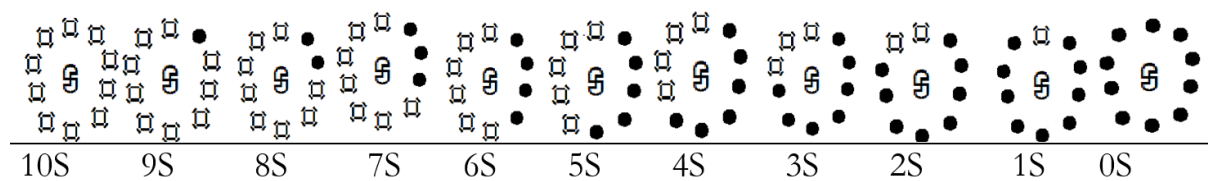
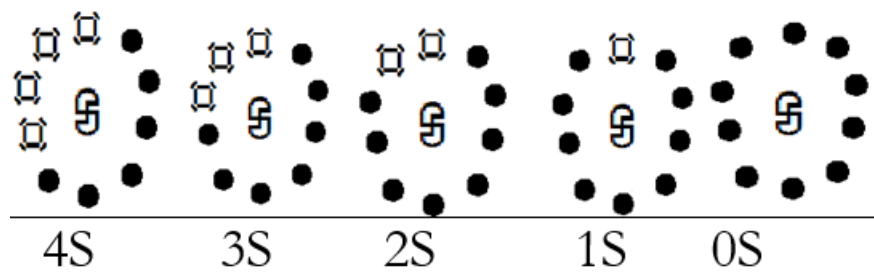
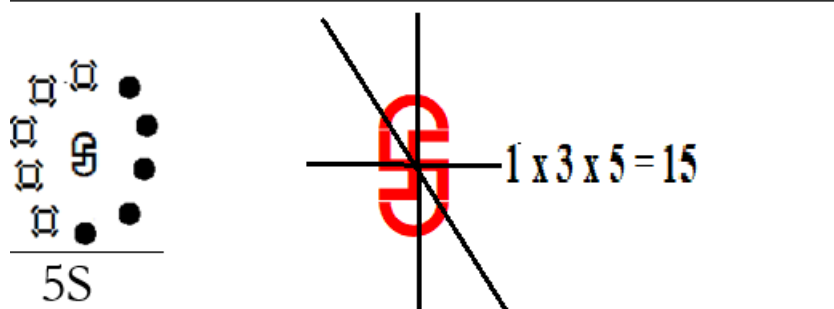
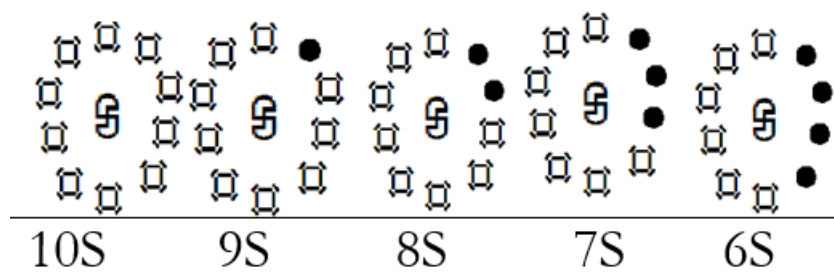

37 9 signatures geometries of 4-space

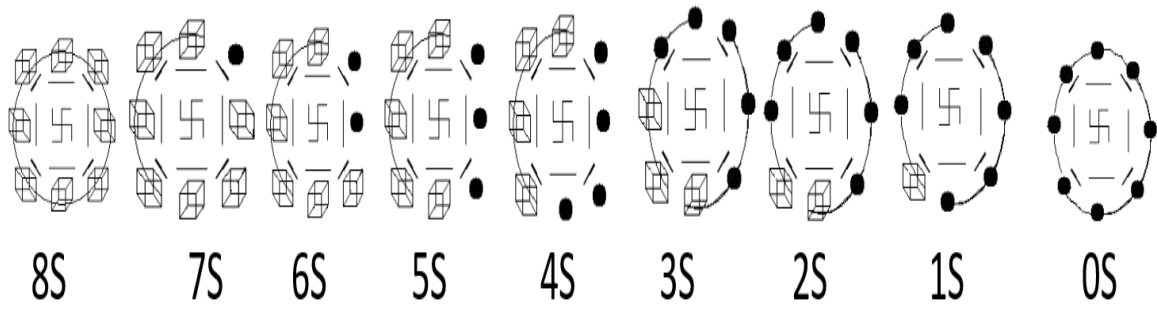

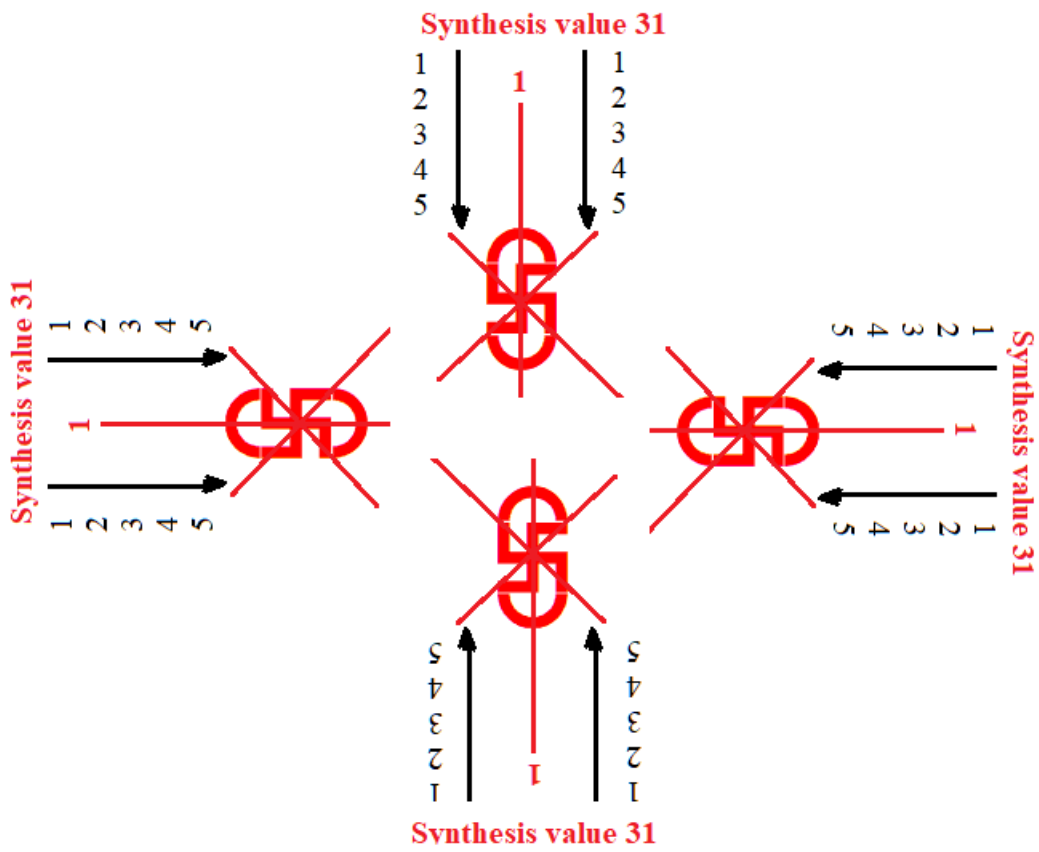

38 Synthesis value 31



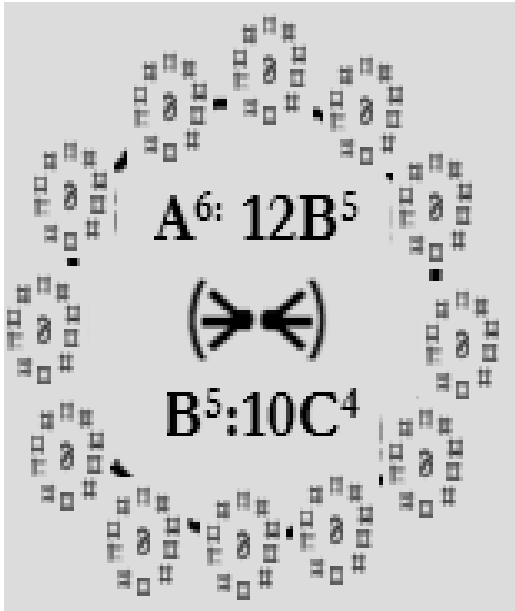





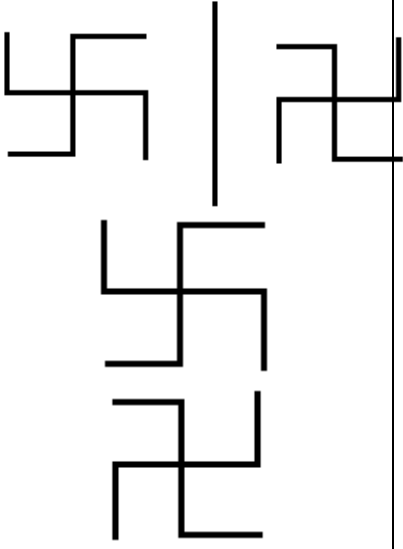

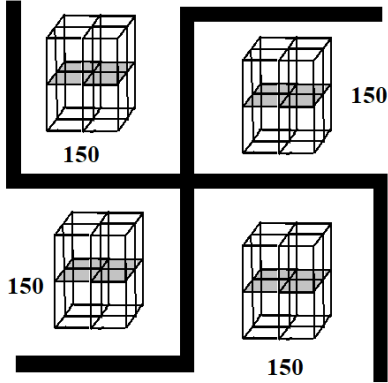

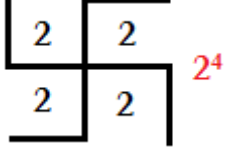

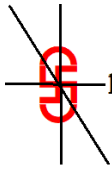

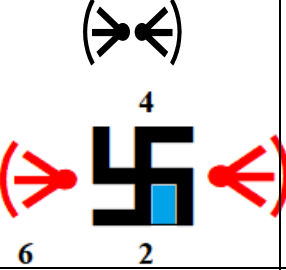

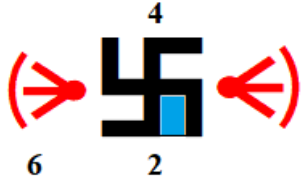

















39 120 hyper cubes



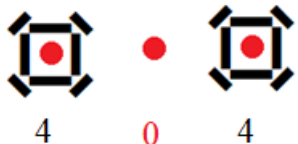

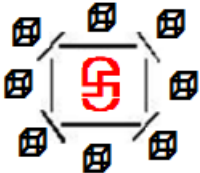







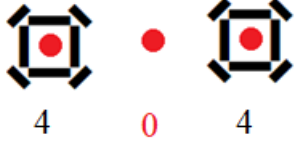

40 Vedic alphabet

Sr	.					
1	a		19 swasti k	I		

						$4 \times 150 = 599 + 1$ 
2	b		20	J	J	
3	c	  $1 \times 3 \times 5 = 15$	21	K		Northern Hemisphere
4	d	 6 2	22	L		 4 6 2
5	e		23	M		
6	f		24	N		 7-space
7	g		25	O		
8	h		26	P		

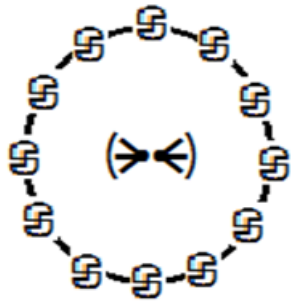
9	i		27	Q		
1 0	j		28	R		
1 1	A		29	S		<p>Transcendental seal at origin seat of 4-space</p> 
1 2	B		30	T		<p>Transcendental space Paramvihom (परमवियोम्) TCV (परमवियोम्)=44</p> 
1 3	C		31	U		<p>Hyper cube 5 (2, 3, 4, 5)</p> 
1 4	D		32	V		<p>Transcendence of origin Transcendence spectrum</p> 

1 5	E		33	W		<p>Transcendental space of self referral features</p> <p>Paramvihom (परमवियोम्) TCV (परमवियोम्)=44</p>  <p>Self referral features</p> 
1 6	F		34	X		 
1 7	G		35	Y		<p>Hyper Cube 6</p>  <p>$A^6:12B^5$ $12 \times 5 = 60$</p>

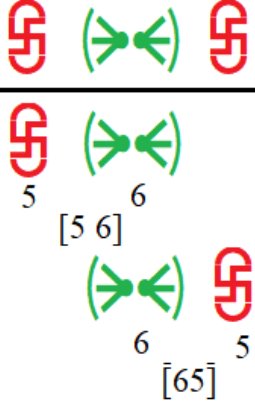
1 8	H		36	Z		<p>Transcendental space of self referral features</p> <p>Self referral features</p> 
--------	---	---	----	---	---	---

41 Cube structure

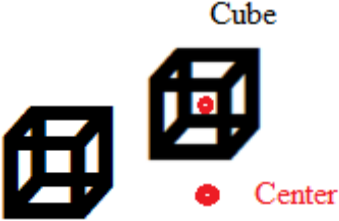
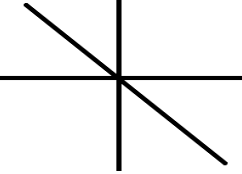
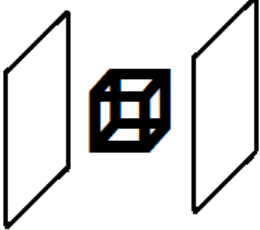
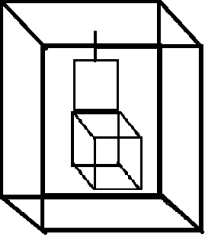
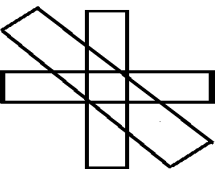
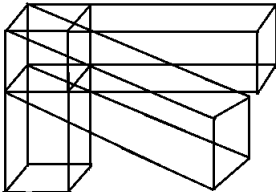
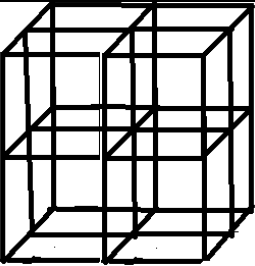
 <p style="text-align: center;">Cube</p>		
 <p style="text-align: center;">triloki</p>		
 <p style="text-align: center;">Eight sub cubes</p>		

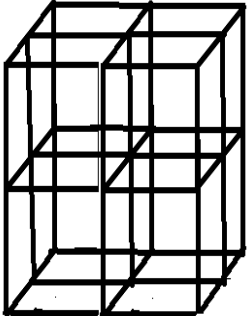
<p>Synthetic Cube of eight sub cubes</p> 	<p>Structural components of eight sub cubes</p> <p>125</p> <p>27 + 18 + 18 + 12</p> <p>+ 12 + 18 + 8 + 12</p>
--	--

42 Separation base plate – synthetic cube of eight sub cube

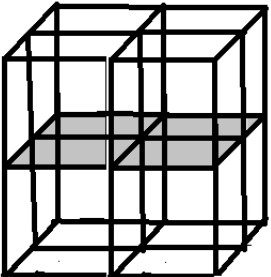
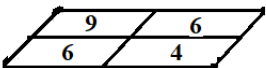
<p>Structural component of upper quadruple sub cubes</p> <p>$27 + 18 + 18 + 12 = 75$</p> <p>Structural component of lower quadruple sub cubes</p> <p>$18 + 12 + 12 + 8 = 45$</p>	<p>Synthetic Cube of eight sub cubes</p> 	<p>Separation base plate</p>  <p>Synthetic set up of quadruple quarter squares of structural components</p> <p>$9 + 6 + 6 + 4 = 25$</p>
---	---	--

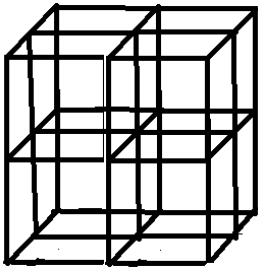
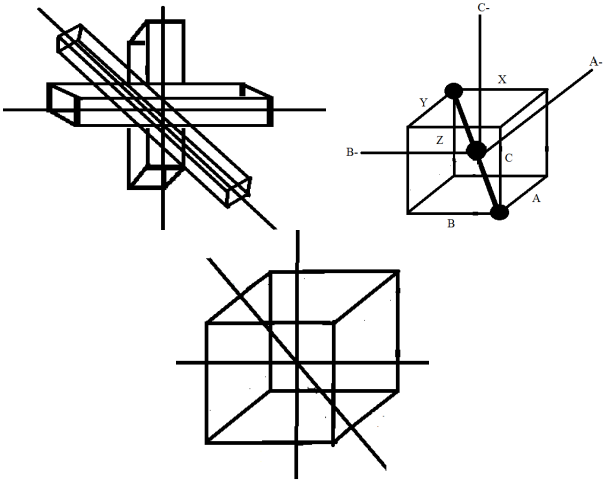

43 Eight sub cubes

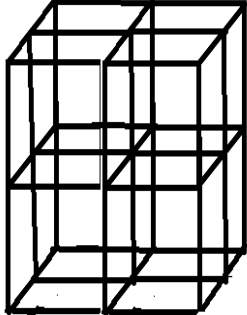
<p>Synthetic Cube of eight sub cubes</p> 	<p>Structural components of eight sub cubes</p> <p>125</p> <p>27 + 18 + 18 + 12</p> <p>+ 12 + 18 + 8 + 12</p>
---	---

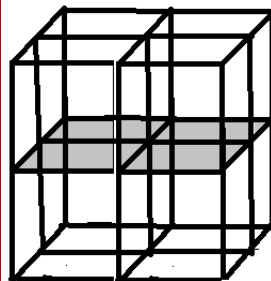
<p>Structural component of upper quadruple sub cubes $27 + 18 + 18 + 12 = 75$</p> <p>Structural component of lower quadruple sub cubes $18 + 12 + 12 + 8 = 45$</p>	<p>Synthetic Cube of eight sub cubes</p> 	<p>Separation base plate</p> <table border="1" style="margin-left: auto; margin-right: auto;"> <tr> <td style="padding: 5px;">9</td> <td style="padding: 5px;">6</td> </tr> <tr> <td style="padding: 5px;">6</td> <td style="padding: 5px;">4</td> </tr> </table> <p>Synthetic set up of quadruple quarter sequares of structural components $9 + 6 + 6 + 4 = 25$</p>	9	6	6	4
9	6					
6	4					

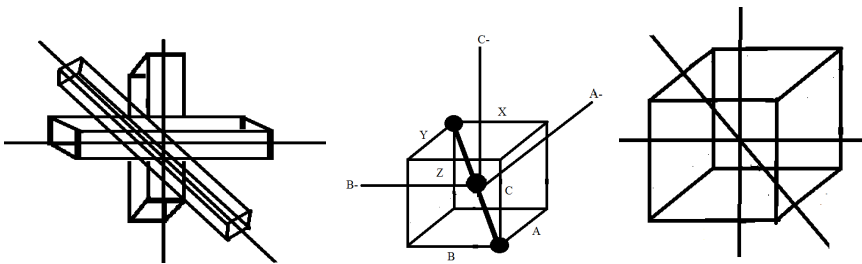

44 Home of lord brahma and vidhyadhari within shila

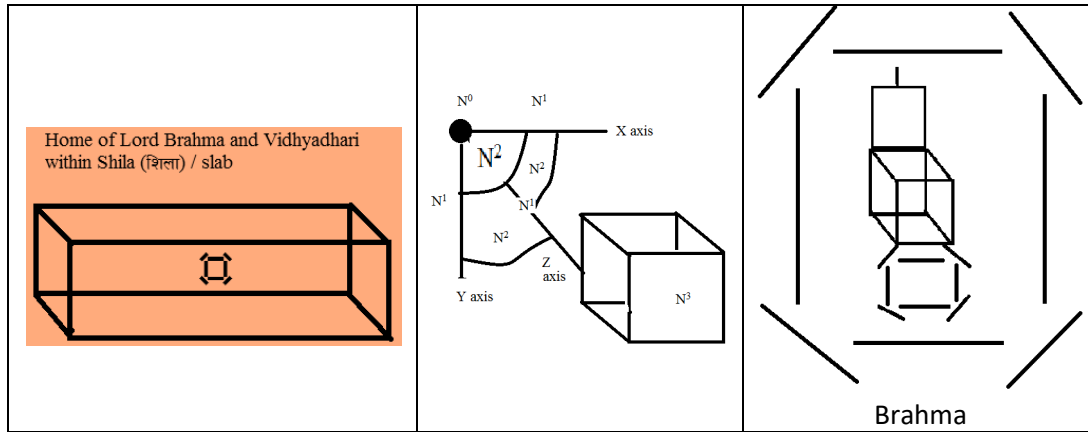

45 Northern hemisphere

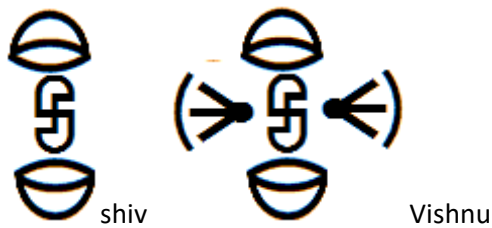



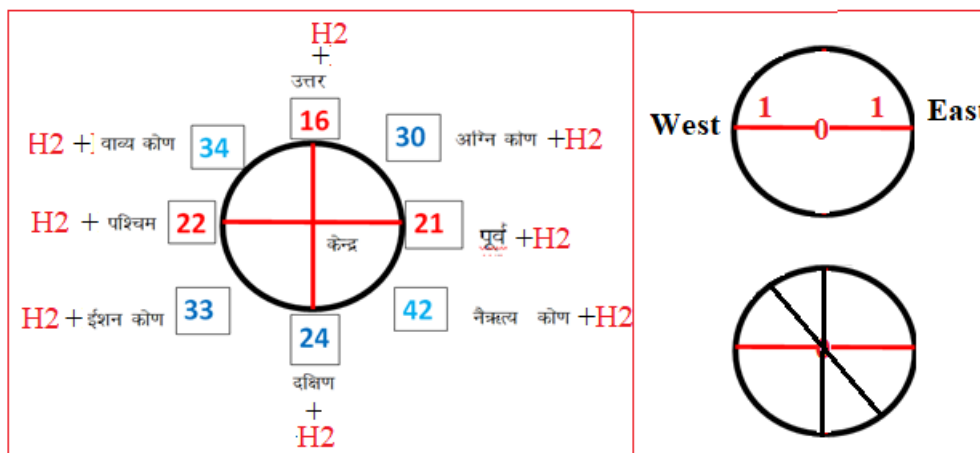

46 Eight directional frame

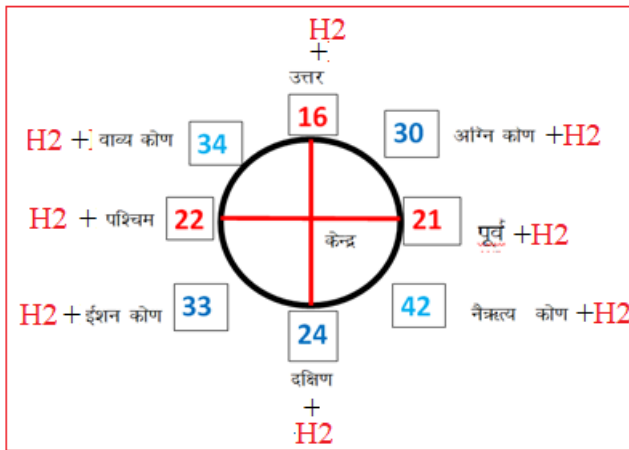
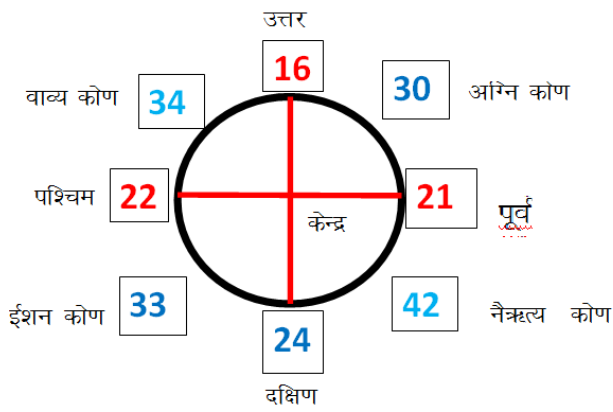
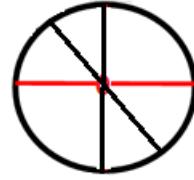
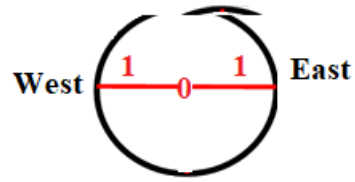
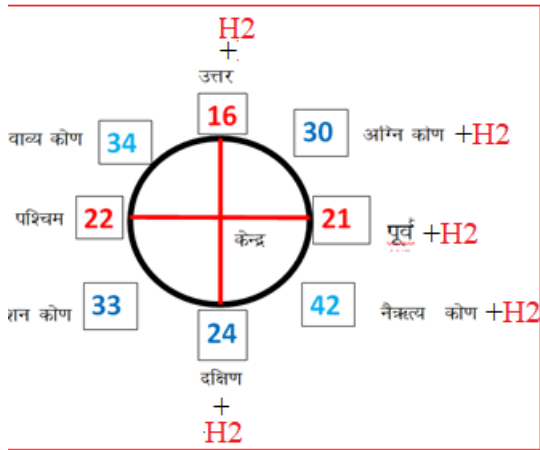



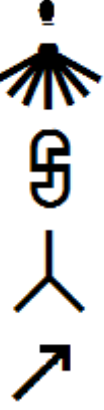
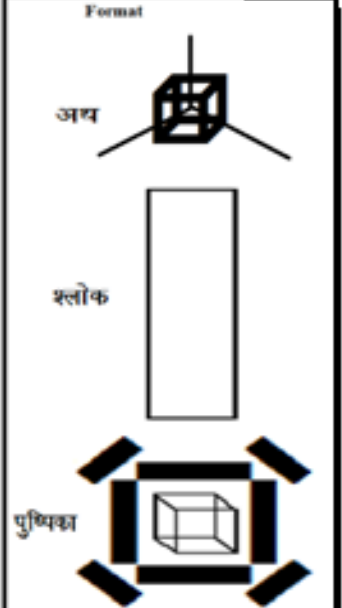
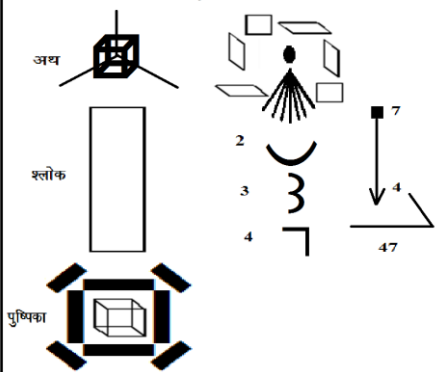
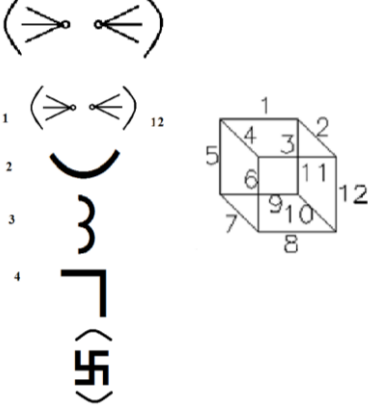
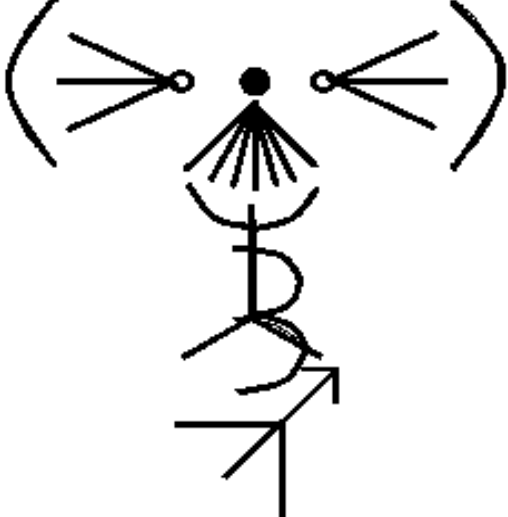

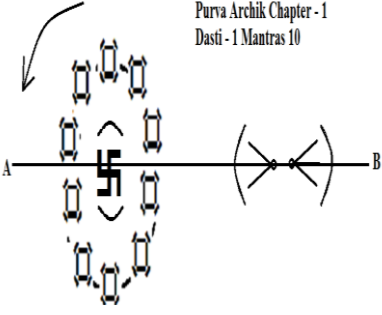
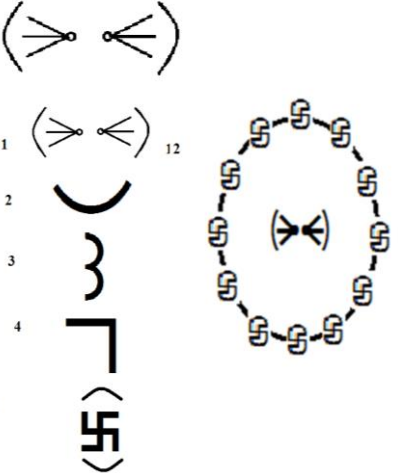
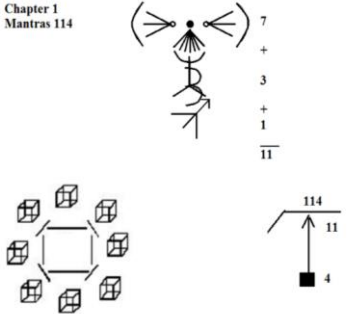
Eight directional

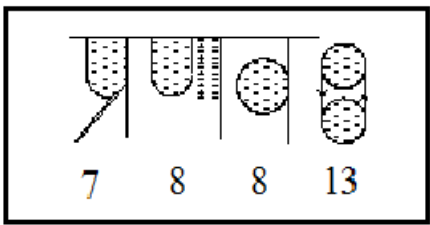
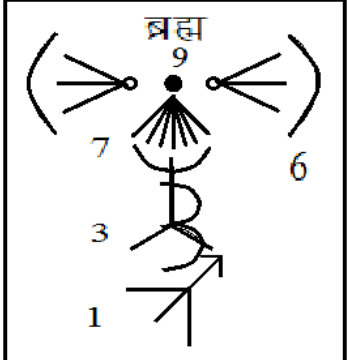

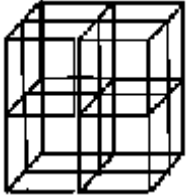

	<p>9 7</p> 	<p>9 1 7 2 3 3 1 4</p> 	<p>9 7 3 1</p> 	<p>9 7 5 3 1</p> 
	<p>Format</p> 	<p>Format Chapter - 1 Shaloka - 47</p> 		
				

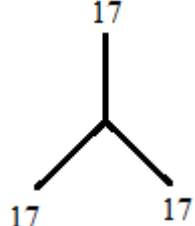

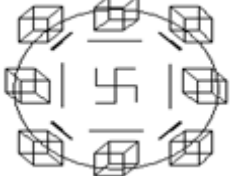
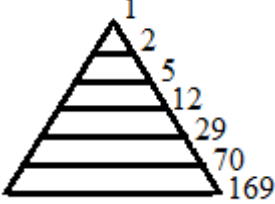

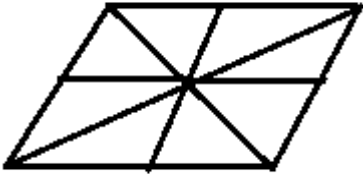





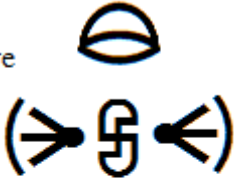

	<p>Purva Archik Chapter - 1 Dasti - 1 Mantras 10</p> 		
	<p>Purva Archik Chapter 1 Mantras 114</p> 		
	<p>बिन्दुसरोवर अर्धमात्रा त्रिपुण्ड्रं स्वास्तिकपाद</p> 	<p>Sama Parvah</p> 	<p>Sama parvah</p>
	<p>Divya Ganga Parvah</p> 		<p>Divya ganga parvah</p>

50 Satha patya figures



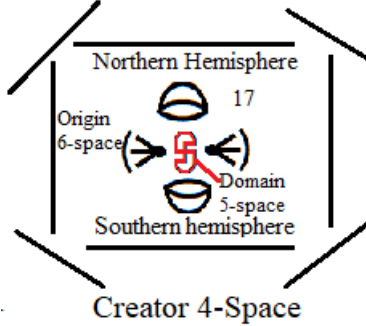

																								
																								
																								
																								
																								
																								
	 <p style="text-align: center;">Domain Split Spectra</p> <table style="margin-left: auto; margin-right: auto;"> <tr> <td style="padding-right: 10px;">Domain</td> <td style="text-align: center;">1</td> <td style="border-left: 1px solid black; padding-left: 10px;">0</td> </tr> <tr> <td>First phase</td> <td style="text-align: center;">2</td> <td style="border-left: 1px solid black; padding-left: 10px;">1</td> </tr> <tr> <td>Second phase</td> <td style="text-align: center;">5</td> <td style="border-left: 1px solid black; padding-left: 10px;">2</td> </tr> <tr> <td>Third phase</td> <td style="text-align: center;">12</td> <td style="border-left: 1px solid black; padding-left: 10px;">3</td> </tr> <tr> <td>Fourth phase</td> <td style="text-align: center;">29</td> <td style="border-left: 1px solid black; padding-left: 10px;">4</td> </tr> <tr> <td>Fifth phase</td> <td style="text-align: center;">70</td> <td style="border-left: 1px solid black; padding-left: 10px;">5</td> </tr> <tr> <td></td> <td style="text-align: center;">169</td> <td></td> </tr> </table>	Domain	1	0	First phase	2	1	Second phase	5	2	Third phase	12	3	Fourth phase	29	4	Fifth phase	70	5		169		<p>Domain split spectrum</p>	
Domain	1	0																						
First phase	2	1																						
Second phase	5	2																						
Third phase	12	3																						
Fourth phase	29	4																						
Fifth phase	70	5																						
	169																							

			
	<p>उत्तर</p> <p>वायव्य कोण 34 16 30 अग्नि कोण</p> <p>पश्चिम 22 21 पूर्व</p> <p>ईशान कोण 33 24 42 नैऋत्य कोण</p> <p>दक्षिण</p> 		

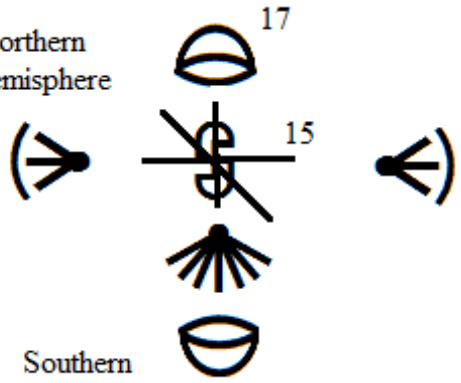
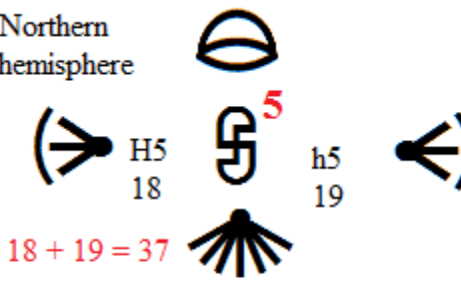
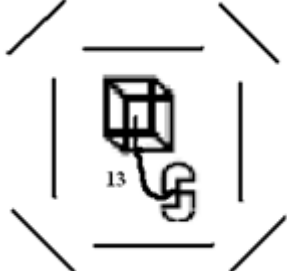
51 Northern hemisphere

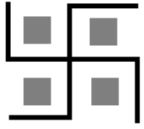
<p>Northern hemisphere</p>  <p>7</p> <p>Southern hemisphere</p>  <p>19</p> <table border="1" data-bbox="207 1489 590 1747"> <tr> <td>Northern hemisphere</td> <td>Northern hemisphere</td> </tr> <tr> <td> 17</td> <td> 17</td> </tr> <tr> <td></td> <td> 71</td> </tr> </table>	Northern hemisphere	Northern hemisphere	 17	 17		 71	 <p>Northern Hemisphere 17</p> <p>Origin 6-space</p> <p>Domain 5-space</p> <p>Southern hemisphere</p> <p>Creator 4-Space</p>
Northern hemisphere	Northern hemisphere						
 17	 17						
	 71						

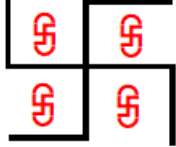
<p>Northern hemisphere</p>  <p>Southern hemisphere</p>	
<p>Northern hemisphere</p>  <p>Southern hemisphere</p> <p>$= 18 + 19 = 37$</p> <p>$37 \times 5 = 185$</p>	
 <p>$1 + 2 + 3 + 4 + 5$ 1 $1 + 2 + 3 + 4 + 5$</p> <p>31</p> <p>$31 \times 13 = 403$</p>	

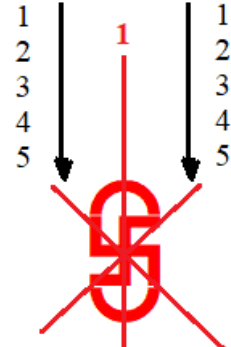
<p>Figure 1</p>	<p>Five geometries of 2-space</p>  <p>G_5^2 Five geometries of 2-space</p>	<p>52 5 geometries of 2-space</p>
<p>Figure 2</p>		<p>53 3 space origin of 2-space</p>
<p>Figure 3</p>		<p>54 5-space origin of 4-space of spatial order</p>
<p>Figure 4</p>	 <p>(3, 5) 3-space dimension 5-space domain</p>	<p>55 3-space dimension of 5-space</p>
<p>Figure 5</p>	 <p>$A^5:10B^4$ $10 \times 4 = 40$</p> <p>Transcendental cavity at origin seat</p>	<p>56 Transcendental cavity at origin seat of creative cap of ten components.</p>
<p>Figure 6</p>	<p>Synthesis value 31</p> 	<p>57 Synthesis of pair of transcendence ranges in spatial dimension of 4-space of 5-space origin.</p>

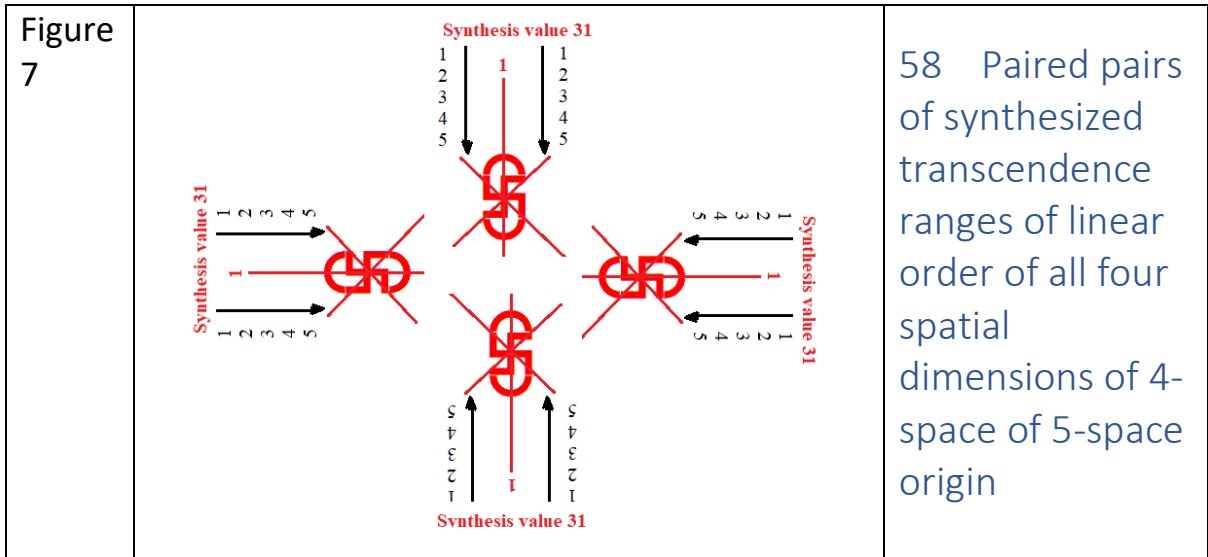

and and imbibe the existence of spatial order 4-space.

<p>Seven geometries of 3-space</p>						
<p>0 signature</p>	<p>1 signature</p>	<p>2 signature</p>	<p>3 signature</p>	<p>4 signature</p>	<p>5 signature</p>	<p>6 signature</p>

To melt spatial order mental state.

Spatial order conditions cognizance within spatial order 4-space of 9 geometries range. To melt this mental state, one is to come out of 4-space room / hyper cube 4, and to comprehend and imbibe the existence of solid order 5-space.

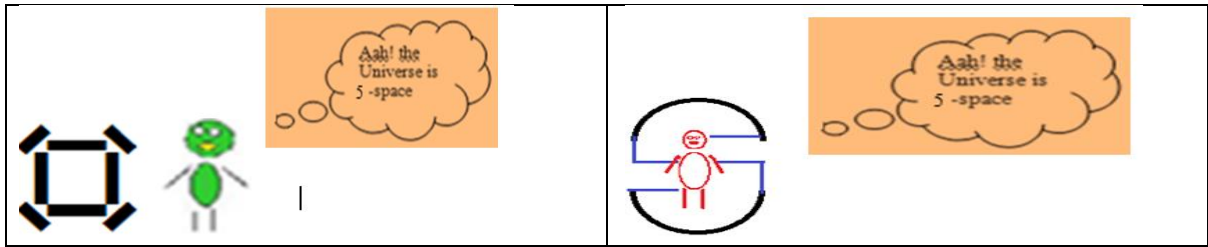

59 Nine signatures geometries of 4-space

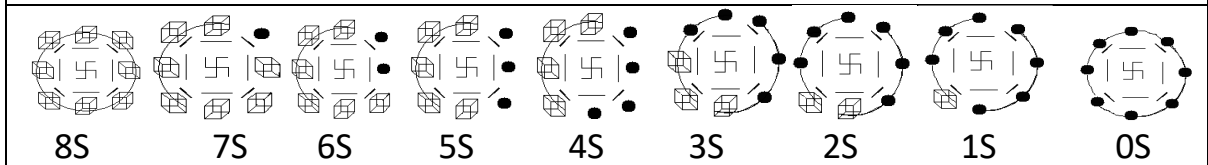

To melt solid order mental state.

Solid order conditions cognizance within solid order 5-space of 11 geometries range. To melt this mental state, one is to come out of 5-space room / hyper cube 5, and to comprehend and imbibe the existence of creative order 6-space.

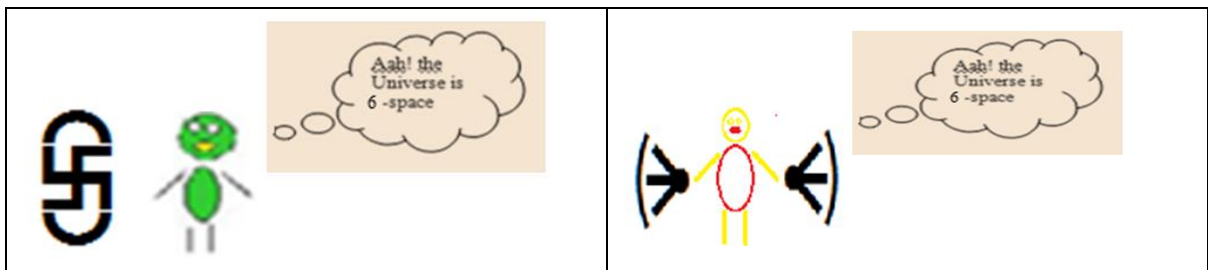

60 Eleven signatures geometries of 5-space

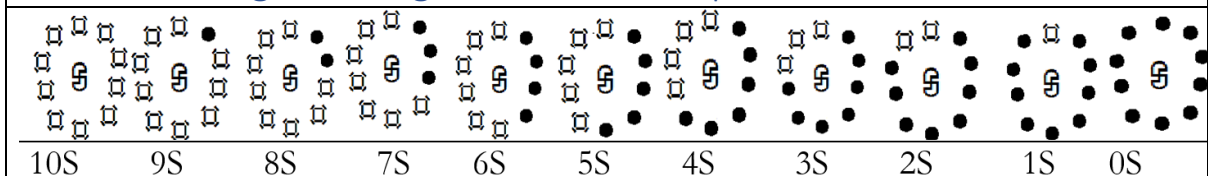

To melt creative order mental state.

Creative (4-space) order conditions cognizance within creative order 6-space of 13 geometries range. To melt this mental state, one is to come out of 6-space room / hyper cube 6 / Sun domain, and to comprehend and imbibe the existence of transcendental order 7-space / Pole star domain.

61 Thirteen geometries of 6-space

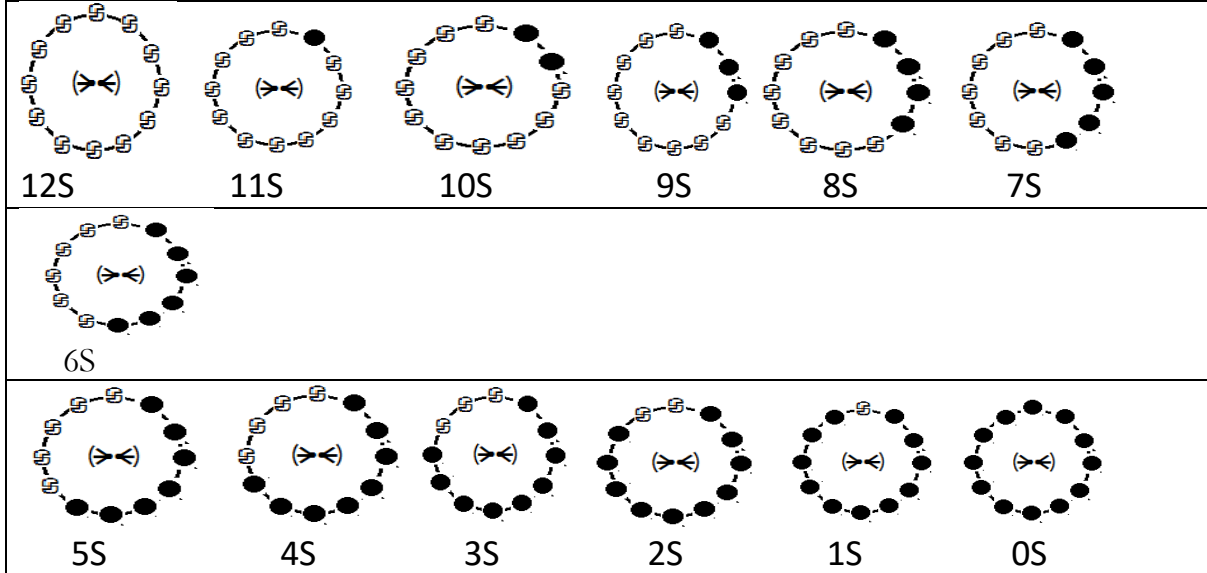

One shall sit comfortably and to permit the transcending mind to be parallel with the sequential placement of five letters of text of first word formulation 'वृद्धि', and to glimpse and imbibe the phenomenon of transcendental (5-space) content flow through each of 7 streams of 7-space origin:

- I. **वृ** of **TCV 7** and of Sathapatya 7-space, of 7 streams at origin seat of 6-space (Surya/Sun).

7 streams flow from 7-space



- II. **ऋ** of **TCV 4** and of Sathapatya 4-space, of creative (4-space) dimensional order of 6-space (Surya/Sun)

Creative (4-space) order of 6-space



- III. **ॠ** of **TCV 6** and of Sathapatya 6-space, as 6-space domain of Surya/Sun.

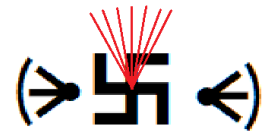

6-space domain

- IV. **ॡ** of **TCV 7** and of Sathapatya 7-space, as 7 streams flow of transcendental (5-space) content manifesting as transcendental boundary of 6-space / Surya/Sun.

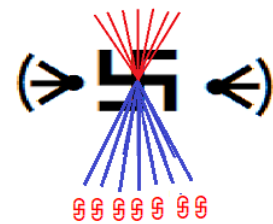

7 streams flow from origin of 6-space

62 Ardh narishwar



63 Agni stabh

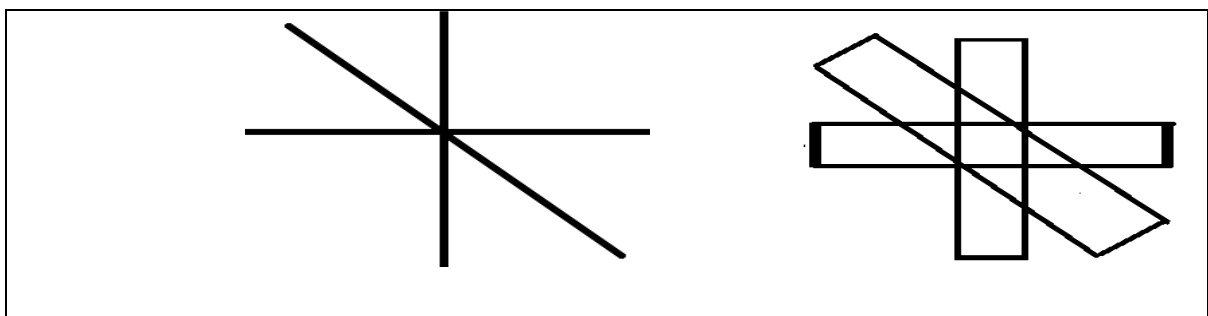

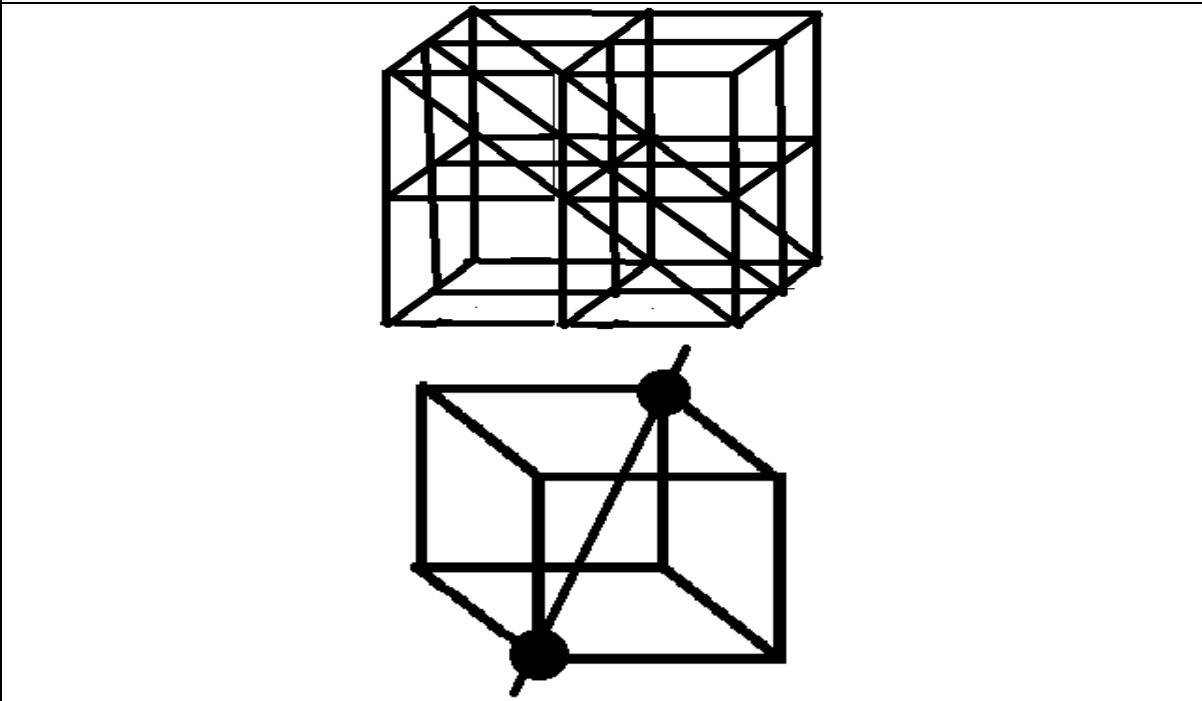
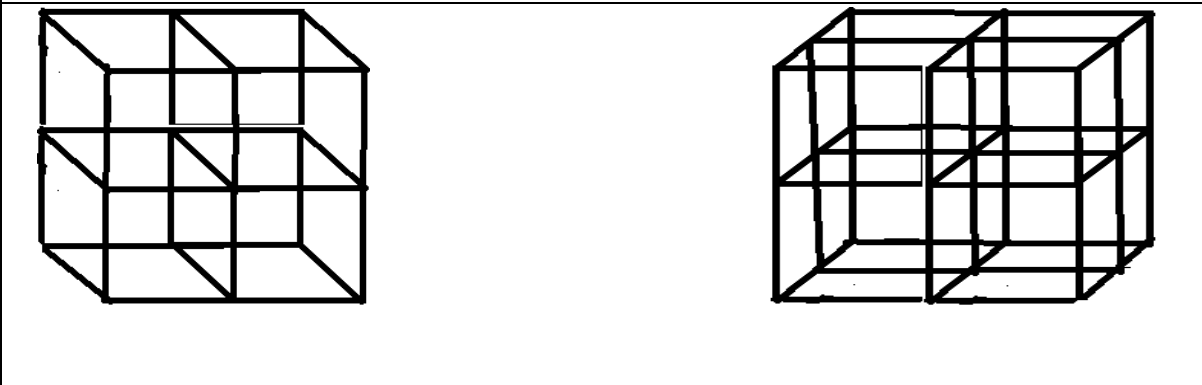
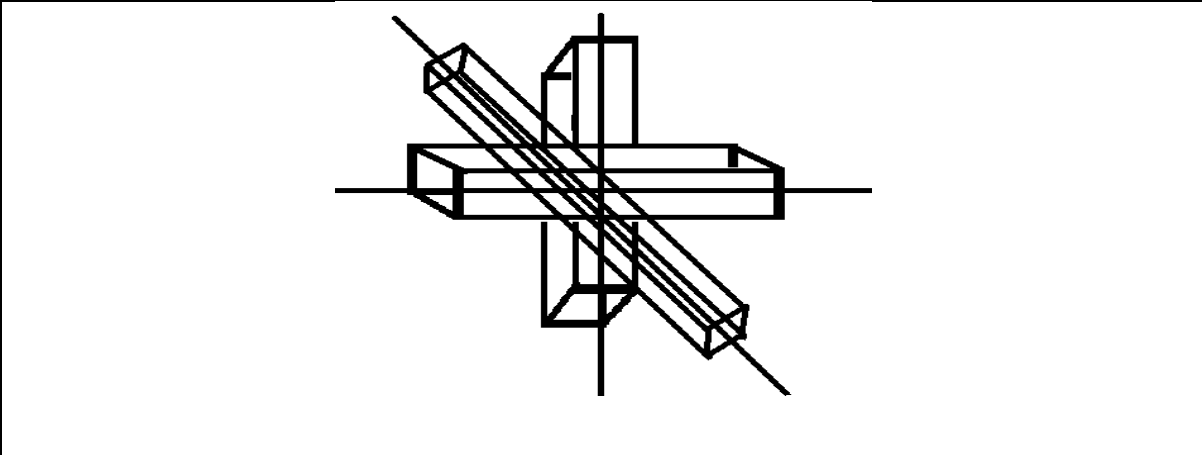

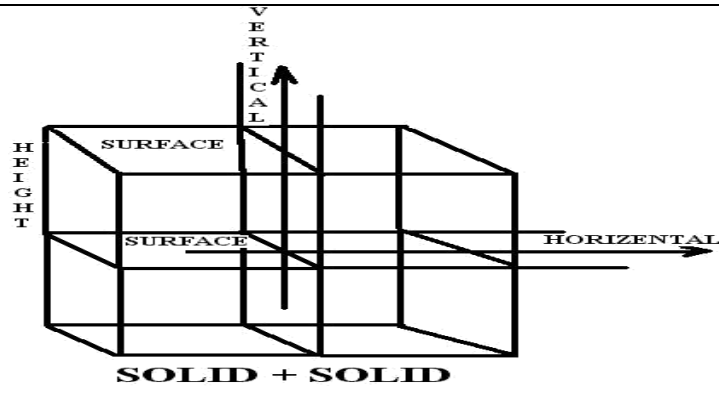

64 Solid plus solid

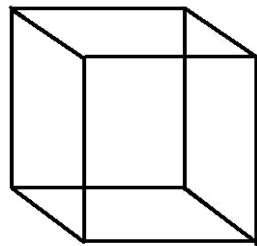

12

FIRE-EDGES

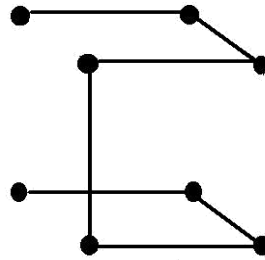

7

FIRE-EDGES

65 Fire edges

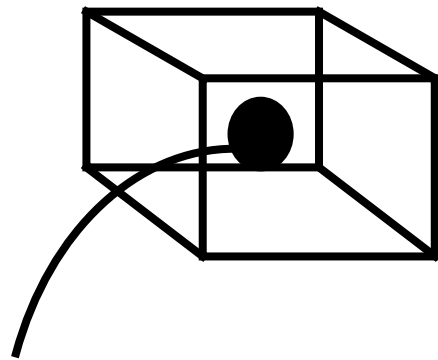
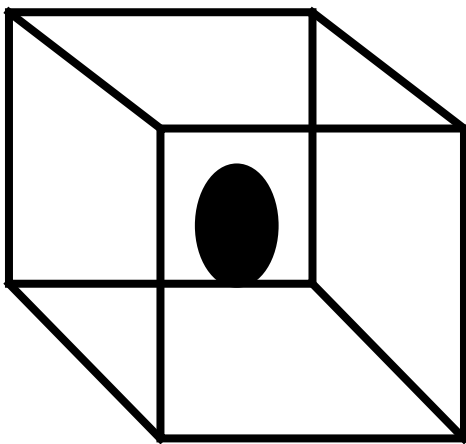

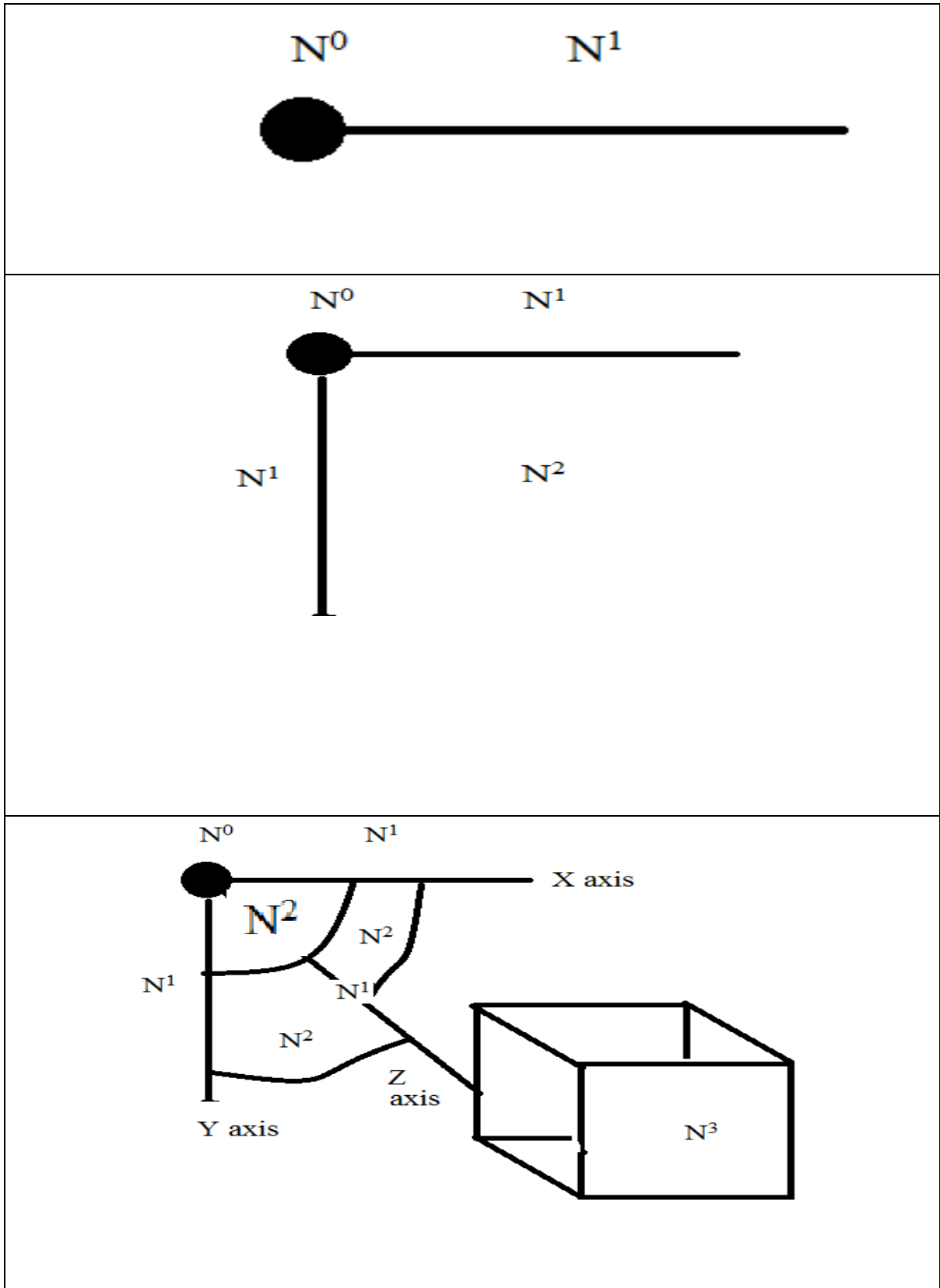

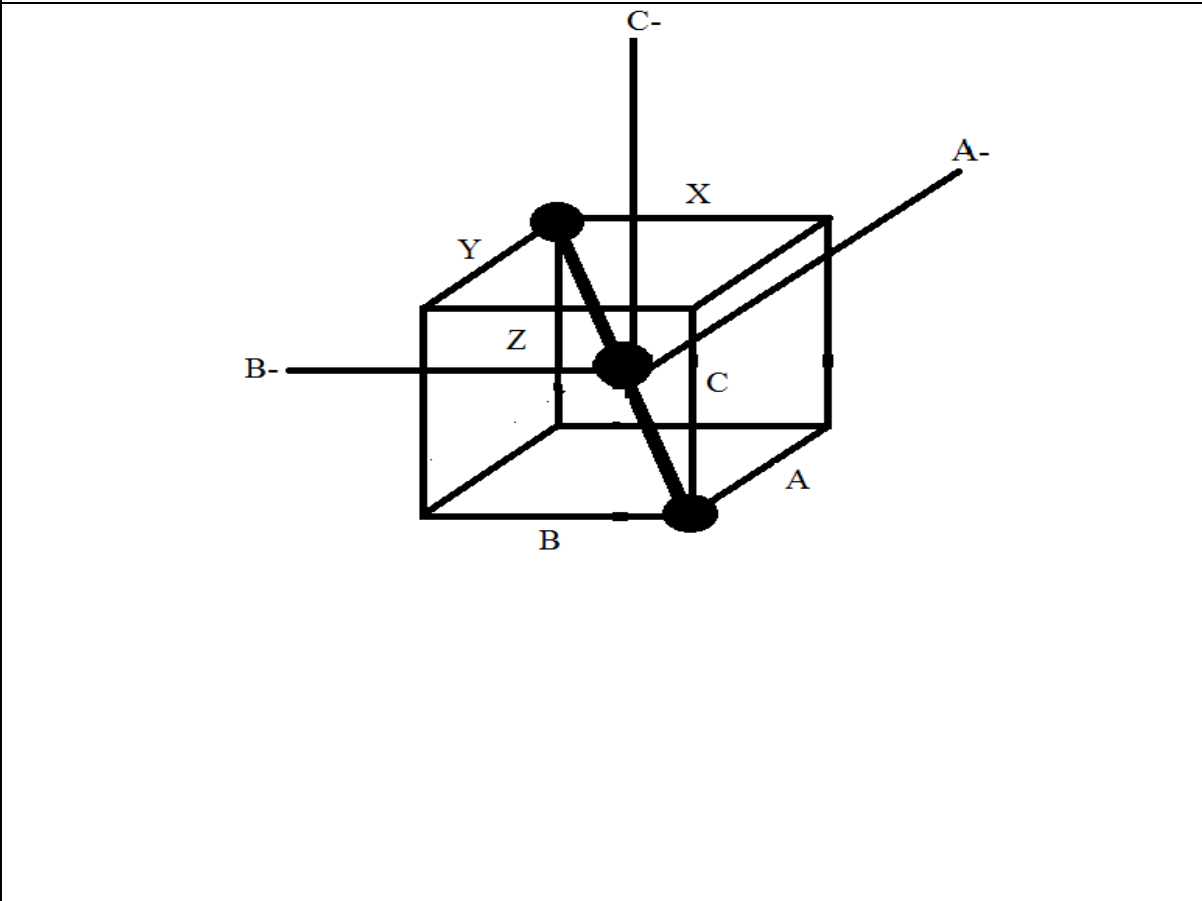
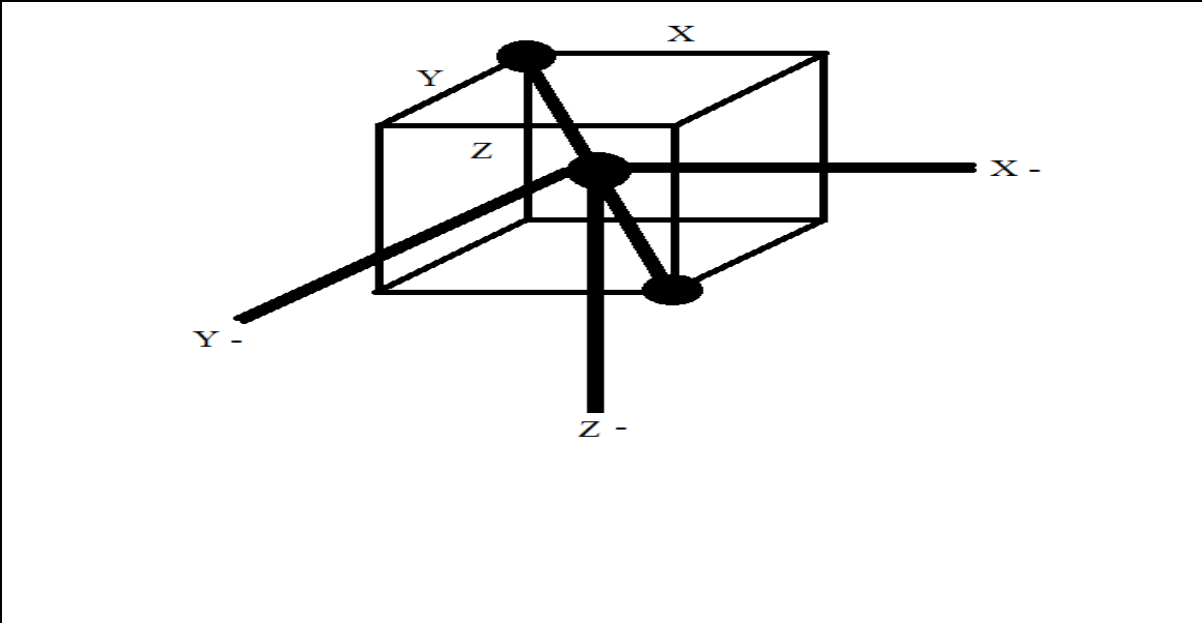

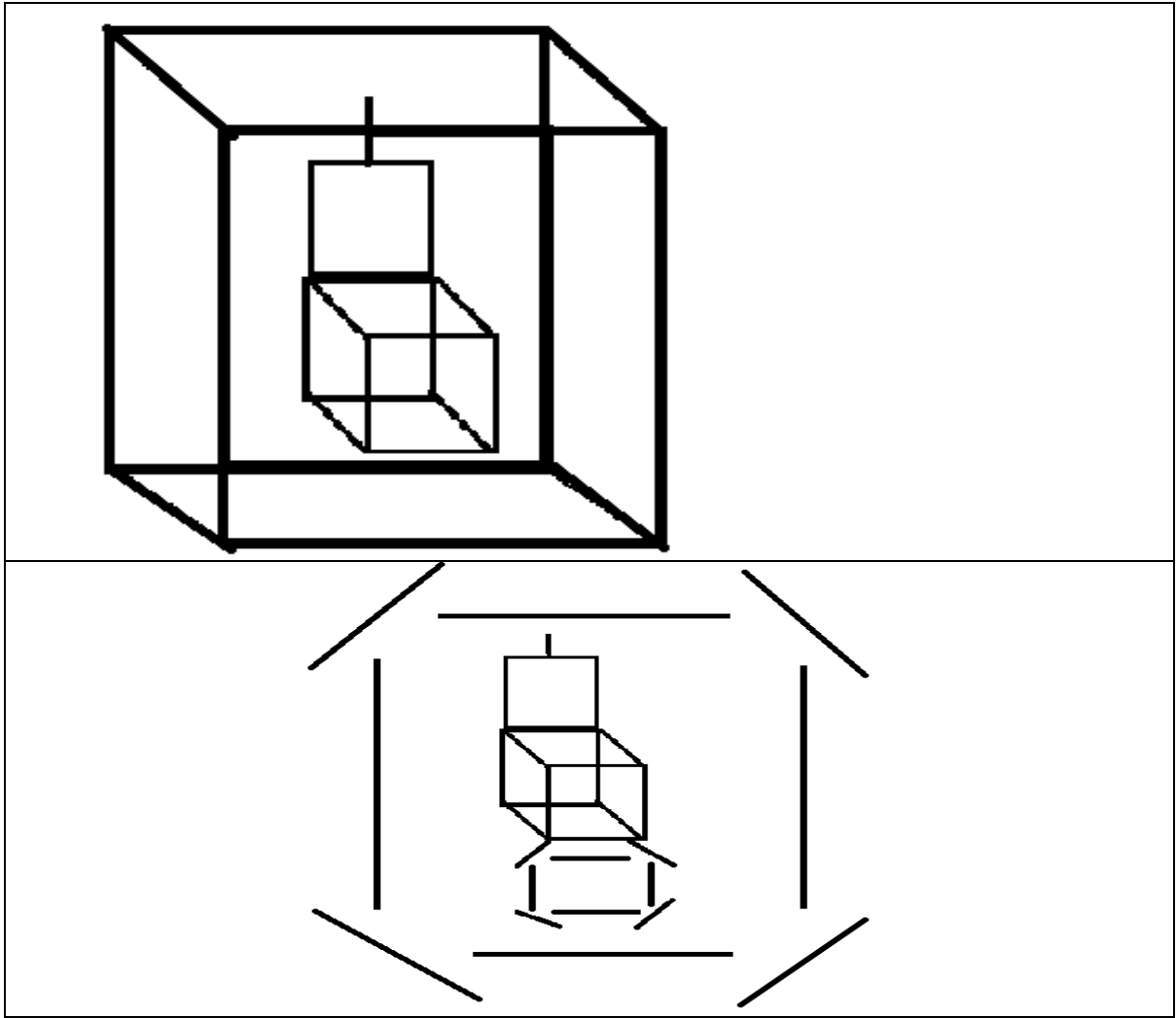

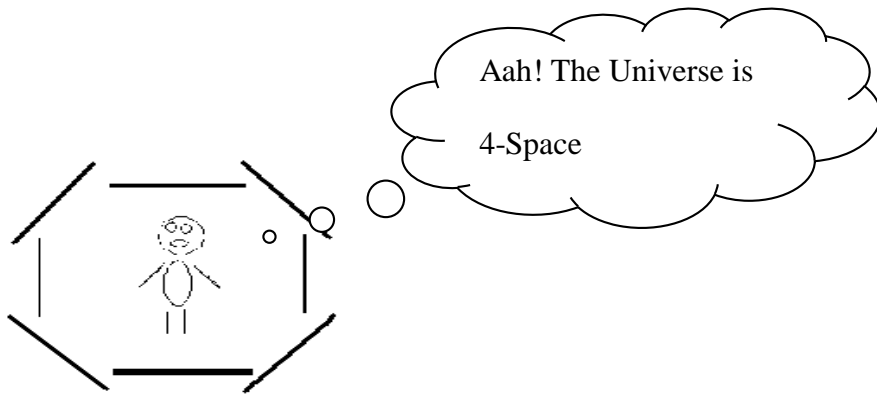
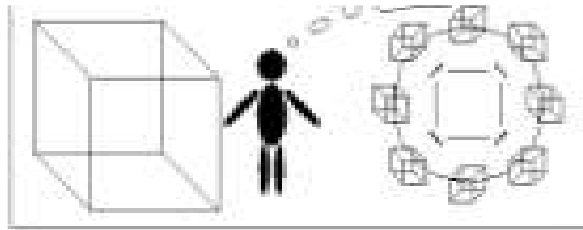
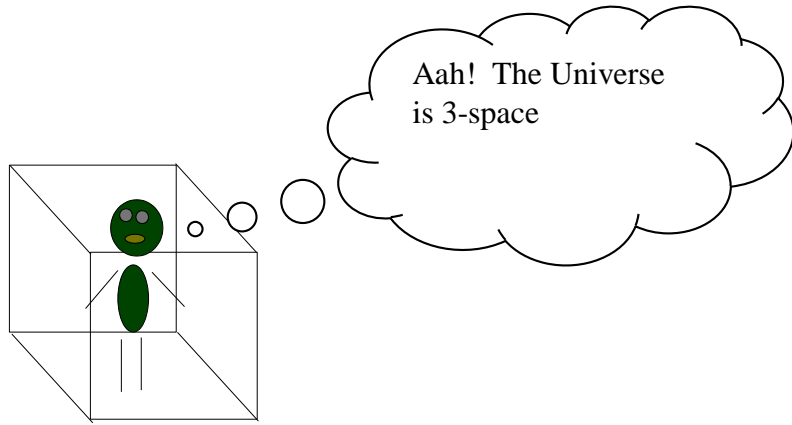

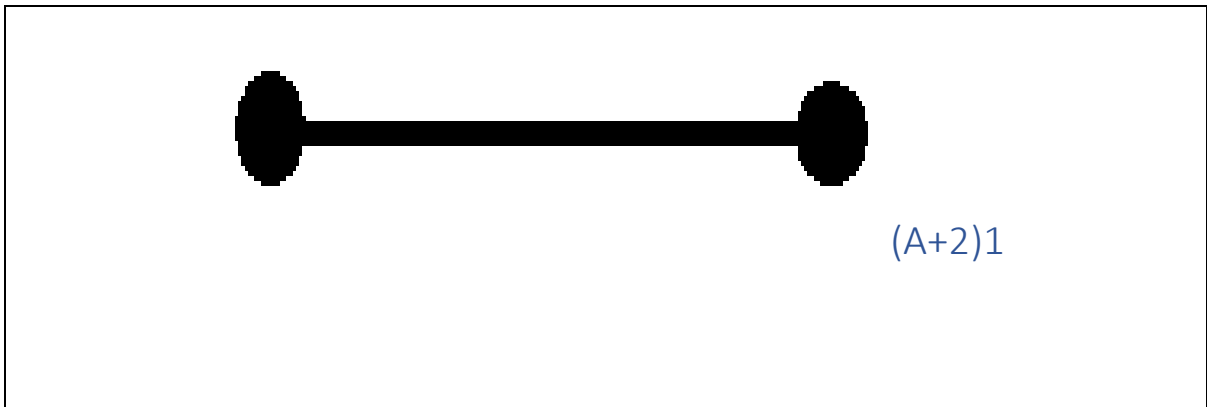
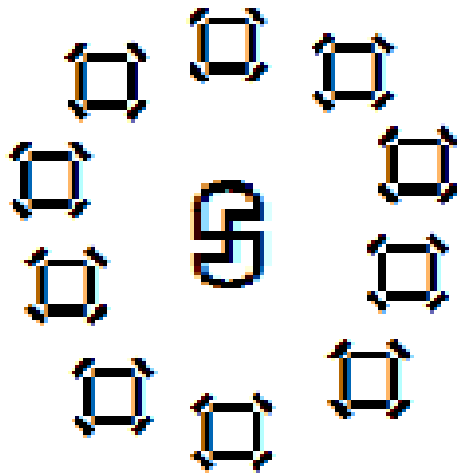
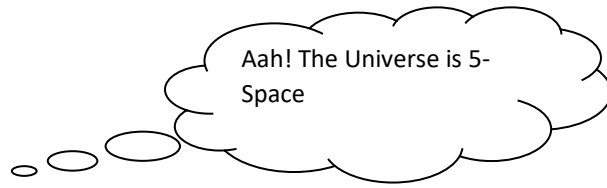
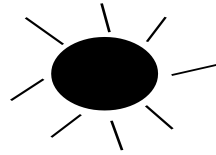
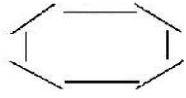

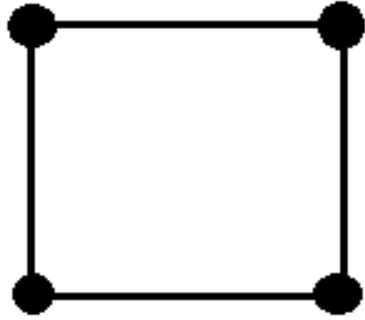

$$(A+2)2$$

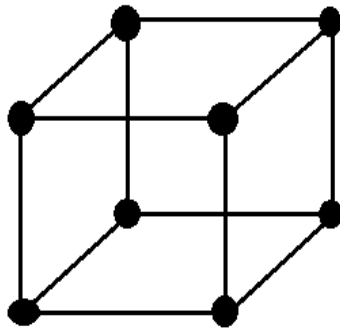

$$(A+2)3$$



$$(2A+3)1$$

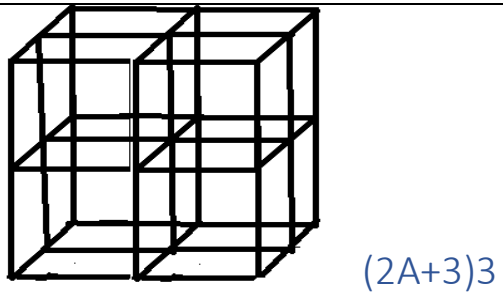
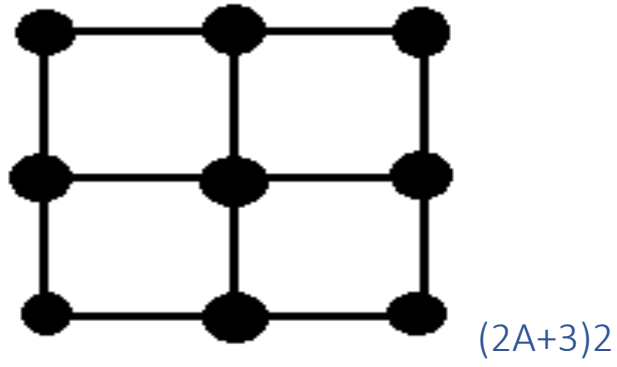

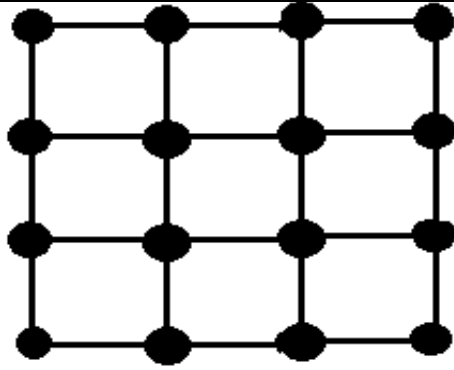

$$(3A+4)2$$

